



By National Cycle

INSTALLATION AND OWNER'S MANUAL

P9BR010A

for Honda VTX1800R/S/N 2004-06 and
VTX1300 R/S 2004-06

Please read and understand these instructions completely before installation to avoid any possible injury to yourself or damage to your motorcycle and / or accessory.

DEALER: These instructions contain important information for future reference and must be given to the customer.

| PARTS LIST | | | | |
|-----------------|---------------|---------------------------------|------|----------------------|
| Item | Part Number | Description | Qty. | Note |
| 1 | 37-371182-000 | Side Plate, Left | 1 | |
| 2 | 37-371183-000 | Side Plate, Right | 1 | |
| BAG #916 | | | | |
| 3 | 34-340519-000 | Spool, Rear | 2 | |
| 4 | 34-340524-000 | Spool, Front | 2 | |
| 5 | 51-516460-000 | Screw, Button M8 x 60 | 2 | |
| 6 | 34-342818-000 | Spacer, Front | 2 | |
| 7 | 44-441901-000 | Cushion, Urethane | 2 | |
| 8 | 34-342817-000 | Spacer, Rear | 2 | |
| 9 | 34-340506-010 | Cover, Rear | 2 | |
| 10 | 51-517161-000 | Screw, Button M10 x 1.25 x 60mm | 2 | |
| 11 | 42-483020-000 | Nut, Hex M8 | 4 | Use in rack assembly |

Report any missing parts directly to National Cycle, Inc. There is important code information located on the end panel of box that will be necessary when reporting missing parts.

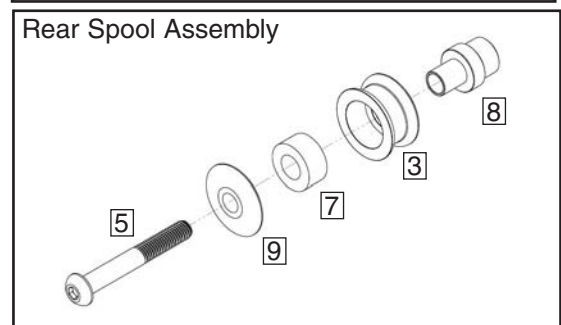
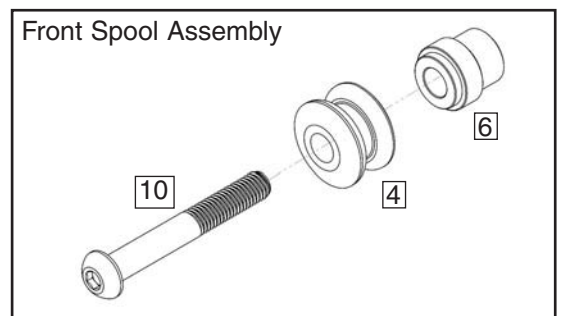
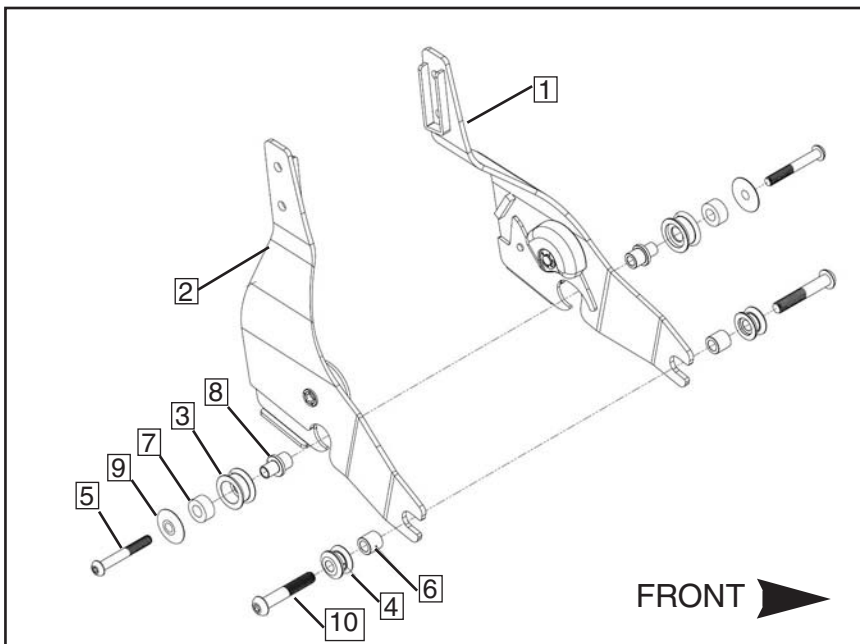

The following symbols are used in these instructions:



Special notes and cautionary measures.



Tips for facilitation of operation, control and adjustment, as well as maintenance work.

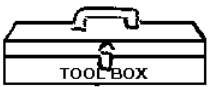

Right and Left side of Motorcycle is determined while sitting on the bike.

Hex Wrench: 5mm (Rear spool assembly, luggage rack/sissy bar)

Hex Wrench: 6mm (Front spool assembly)

Hex Wrench: 5/32" (To attach backrest pad to sissy bar)

Torque wrench: To torque all fasteners

Thread lock: Loctite #234 or comparable

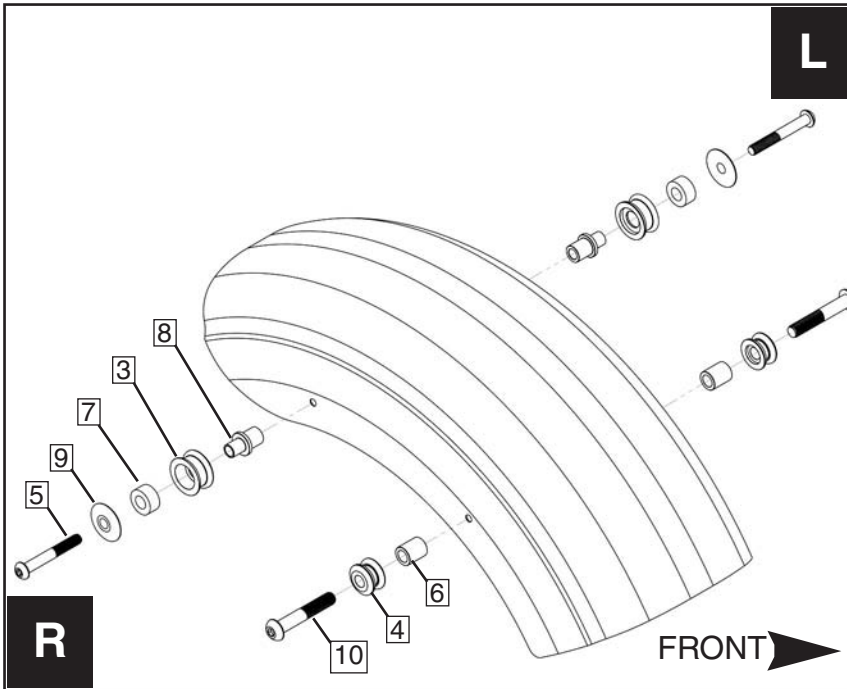

Figure 1

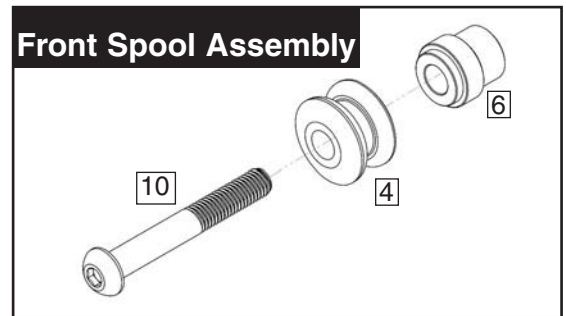
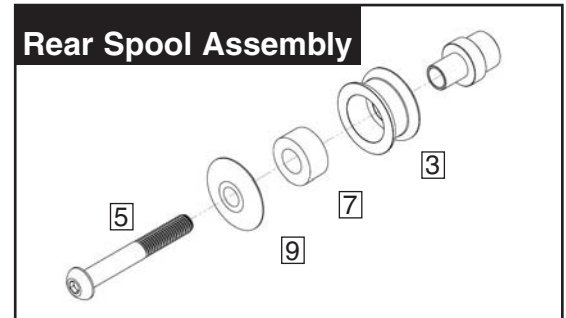

Figure 2

PREPARATION

1. Place motorcycle on flat and level ground with side stand securely in place.



Before installing fasteners we recommend you apply a small amount of Loctite® medium strength #234 thread retaining compound (or similar brand) to the threads of the button head screws (a) referenced on page 3 and to the M8 and M10 fasteners supplied in Bag #916. **(Thread Lock)**

INSTALLATION OF FRONT AND REAR SPOOLS



Avoid misalignment of fender and rail by removing only ONE bolt from the fender trim rail at a time when installing spools. (Reference, step 1 and 2 below)

1. Start on right side of the motorcycle and remove the 2 bolts from the fender trim rail. Bolts will not be re-used.
2. Install front and rear spool assemblies into the right side of fender. Do not fully tighten. This will allow some movement which aids in the side plate installation. **(5 and 6mm Hex Wrench) Figures 1 and 2**



After final assembly fender mount screws will torque to: M8 Screws (Item 5) 22 Nm (17 ft/lb)
M10 Screws (Items 8 and 11) 45 Nm (33 ft/lb)

3. Repeat steps 1-2 for the left side fender assembly.

ASSEMBLY OF BACKREST AND LUGGAGE RACK COMPONENTS

 The Paladin Backrest and Luggage Rack are sold separately. Backrest part no. P9800A; rack part no. P9900.

 Before installing fasteners we recommend you apply a small amount of Loctite® medium strength #234 thread retaining compound (or similar brand) to the threads of the button head screws (a) and to the M8 and M10 screws used to assemble spools (page 2, step 2.) **(Thread Lock)**

1. Assemble side plates (1) and (2) to the Paladin backrest alone or with the Paladin luggage rack. **(5mm Wrench and 13mm Box Wrench) Figure 3.**
2. Use items (a) button head screw and (b) support stay (provided with the backrest kit) and item (11) cap nut (provided in this kit) to complete assembly of the side plates.
3. Torque 8mm screws (a) to 22 Nm (17 ft/lb).

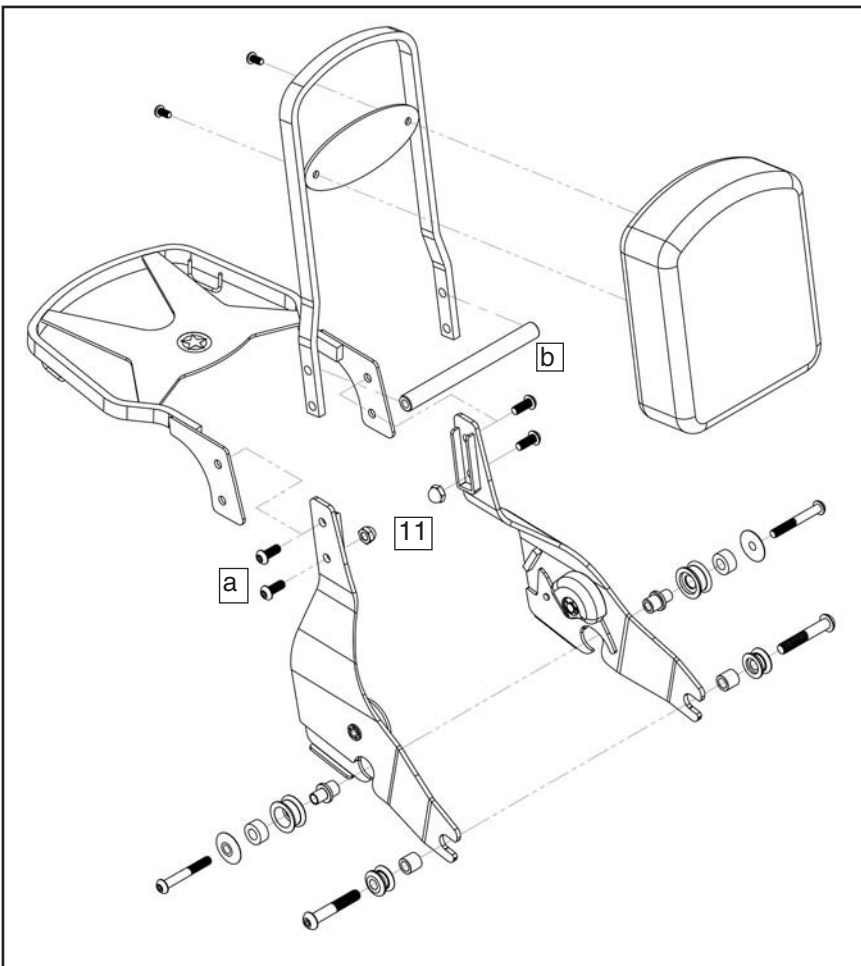

Figure 3

INSTALL ASSEMBLY TO MOTORCYCLE

1. Check that QuickSet is unlocked. Install backrest assembly onto motorcycle by first positioning side plates on front spools. With smooth continuous forward force, rotate the backrest assembly downward on to the rear spools while pushing down firmly to engage side plate latch mechanism with the rear spools. **Figure 4.**

2. Tighten the two M8 screws to 22 Nm (17 ft/lb) and the two M10 screws to 45 Nm (33 ft/lb). **Torque Wrench**

3. Make sure to lock the backrest in place before operating the motorcycle.

4. To remove backrest assembly, stand behind vehicle. Unlock and pull up gently on side plate latch mechanisms. Rotate backrest assembly upward and then pull back to disengage front spools.

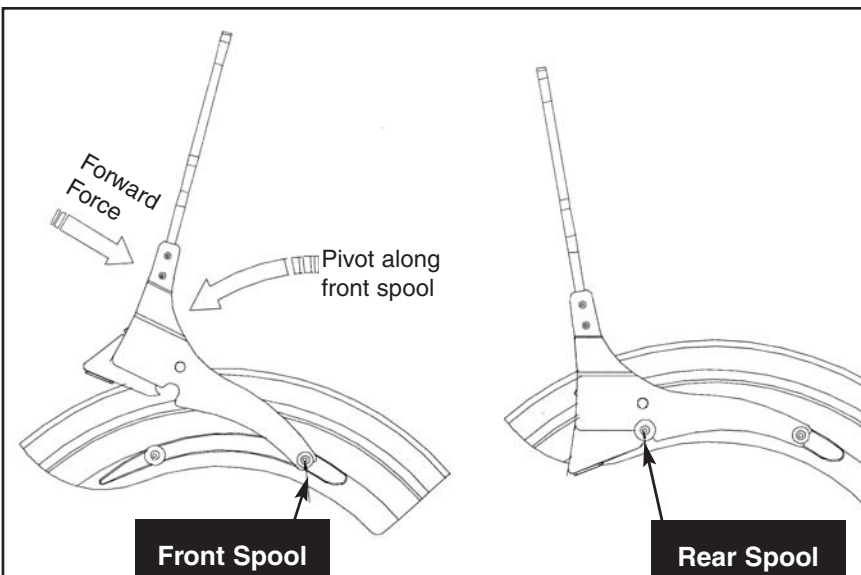



Figure 4

PATENT No. 6484914

INSTALLING PALADIN KIT WITH CRUISELINER SADDLEBAGS

 For this installation you will need the screws from the Cruisliner Saddlebag Kit

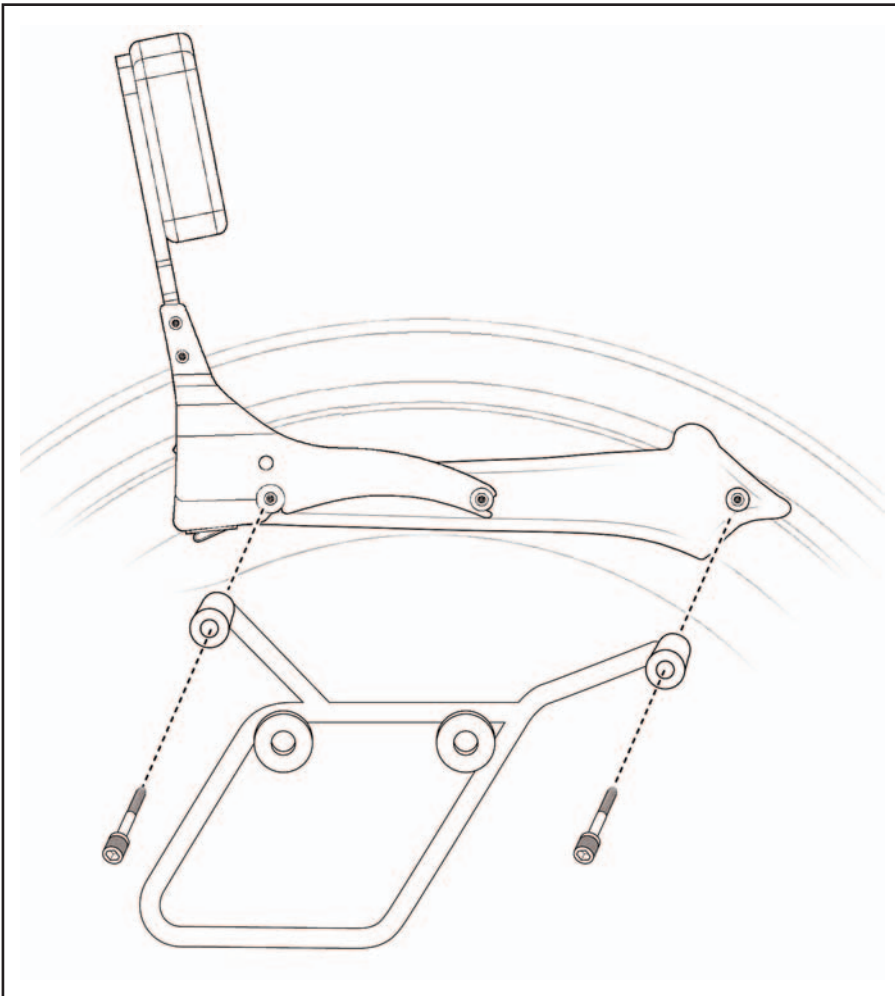



Figure 5

 Before installing fasteners we recommend you apply a small amount of Loctite® medium strength #234 thread retaining compound (or similar brand) to the threads of the screws used to attach the saddlebag frames. **(Thread Lock)**

1. Refer to page two of this instruction manual and install the spool assemblies as instructed.
2. On the right side of the motorcycle remove the stock screws from the front of the fender rail.
3. On the right side of the motorcycle remove the rear screws from the rear spool assembly.
4. Install the frame bracket at the rear mount point using a M8-1.25 x 75 screw from bag #610C of the Cruisliner Kit. The rear bushing from Bag#610C will not be used when mounting Cruisliner bags with Paladin Backrest. **(6mm Hex Key) Figure 5**
5. Install the front mount point of saddlebag frame with the M10-1.25 x 65 screw from this kit. **(8mm Hex Key)**
6. Repeat installation on other side.
7. Tighten screws to: M10 = 45 Nm (33 ft/lb)
M8= 22 Nm (17 ft/lb)

WARNING

Maximum load for the Luggage Rack is 5 Kg (11 lbs).

When mounting the Backrest assembly, listen for the audible "click" indicating that the latches are in place. Always lock the QuickSet 3 Side Mount Plate before using your motorcycle. This insures the utmost in safety.

Never ride your motorcycle with loose accessory mounting hardware. Check the hardware for tightness regularly.

Today's motorcycles are built with enough frame rigidity to withstand the moderate loads imposed on them by the foreseeable addition of an accessory. If the accessory(ies) adversely affects your motorcycle's stability, immediately remove the accessory(ies). Do not ride a motorcycle that exhibits unsafe handling traits.

Have experienced service personnel correct any problem before riding with the accessory(ies) installed. For further questions concerning handling problems associated with an accessory(ies), contact your dealer, motorcycle manufacturer, or accessory manufacturer.

MAINTENANCE

The high quality chrome finish of your National Cycle Paladin rack assembly can be maintained with any quality chrome cleaner and or polish. Overtime spools can be lubricated with any common household lubricant.