



By National Cycle

INSTALLATION AND OWNER'S MANUAL

P9BR305 for installation to Yamaha XVS1100 P Custom and P9BR307 for XVS 1100 A Classic

Please read and understand these instructions completely before installation to avoid any possible injury to yourself or damage to your motorcycle and / or accessory.

DEALER: These instructions contain important information for future reference and must be given to the customer.

PARTS LIST

Item	Part Number	Description	Qty.	Note
1	37-371174-000	Side Plate, Left	1	IN KIT P9BR305
2	37-371175-000	Side Plate, Right	1	IN KIT P9BR305
1A	37-371162-000	Side Plate, Left	1	IN KIT P9BR307
2A	37-371163-000	Side Plate, Right	1	IN KIT P9BR307
3	80-890000-000	Eyebrow, Left	1	Assembled w/ cushion
4	80-890001-000	Eyebrow, Right	1	Assembled w/ cushion
BAG 529				
5	34-340519-000	Spool, Rear	2	
6	34-340518-000	Spool, Front	2	
7	51-516460-000	Screw, M8 x 60	4	
8	34-342808-000	Spacer, Front	2	
9	44-441901-000	Cushion, Urethane	2	
10	34-342809-000	Spacer, Rear	2	
11	34-340506-010	Cover, Rear	2	
12	42-483020-000	Nut, Hex Cap	4	Used to attach back rest, not shown

Report any missing parts directly to National Cycle, Inc. There is important code information located on the end panel of box that will be necessary when reporting missing parts.

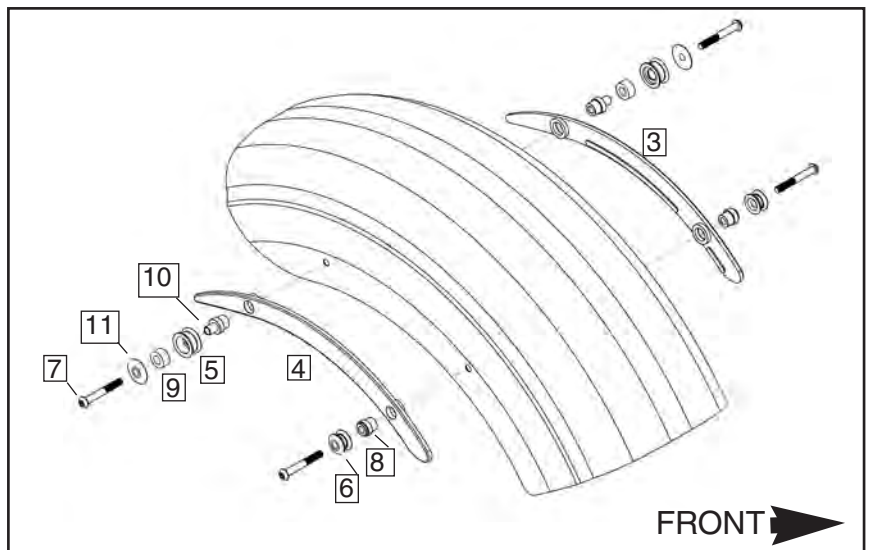
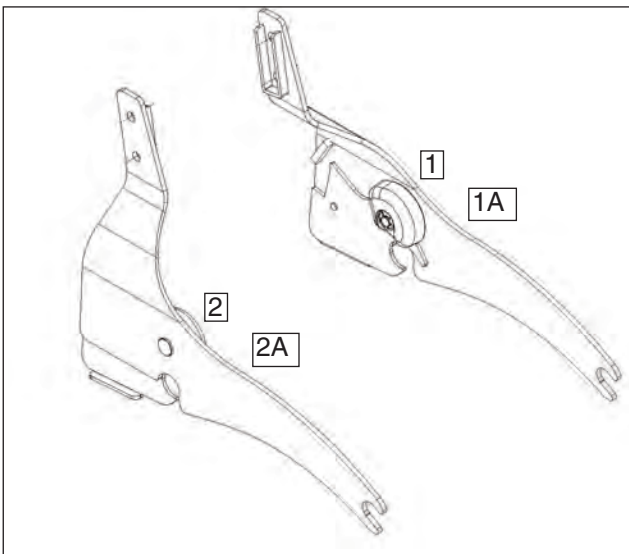

The following symbols are used in these instructions:



Special notes and cautionary measures.



Tips for facilitation of operation, control and adjustment, as well as maintenance work.

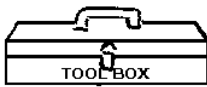

- 5mm Hex Wrench
- 13mm Open End Box Wrench
- Torque Wrench
- Thread Lock, Medium Strength such as Loctite® #234
- 5/32" Hex Wrench (for backrest pad)
- 6mm Hex Wrench (for mounting Paladin® backrest with Cruiseline™ Saddlebags)



Right and Left side of Motorcycle is determined while sitting on the bike.

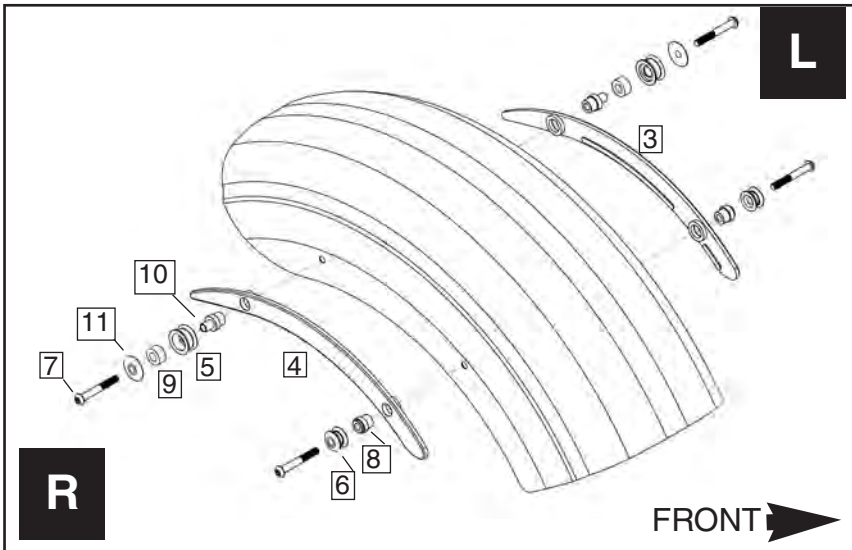

Figure 1

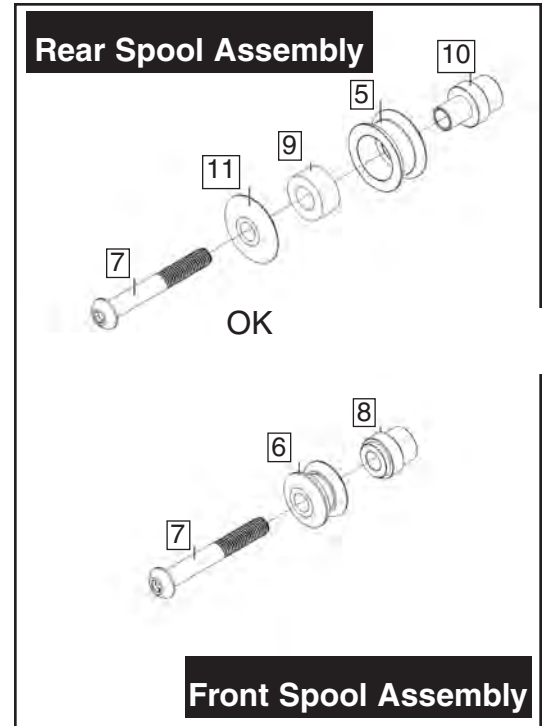

Figure 2

PREPARATION

1. Place motorcycle on flat and level ground with side stand securely in place.



Before installing fasteners we recommend you apply a small amount of Loctite® medium strength #243 thread retaining compound (or similar brand) to the threads of the button head screws (a) referenced on page 3 and to the M8 fasteners supplied in Bag 529. **(Thread Lock)**

INSTALLATION OF EYEBROW

1. Start on right side of the motorcycle and remove the 2 bolts (inside the fender) holding the fender trim rail. Remove the trim rail and set aside. Store bolts and trim rails, they will not be re-used. **(5mm Hex Wrench)**

SPOOL ASSEMBLY, FRONT AND REAR

2. Assemble front and rear spool assemblies into the right eyebrow (4) and into the fender. Do not fully tighten. This will allow some movement which aids in the side plate installation. **(5mm Hex Wrench and Thread Lock) Figures 1 and 2**
3. Repeat steps 1-2 for the left side fender assembly.



After final assembly fender mount screws will torque to: 22 Nm (17 ft/lb)

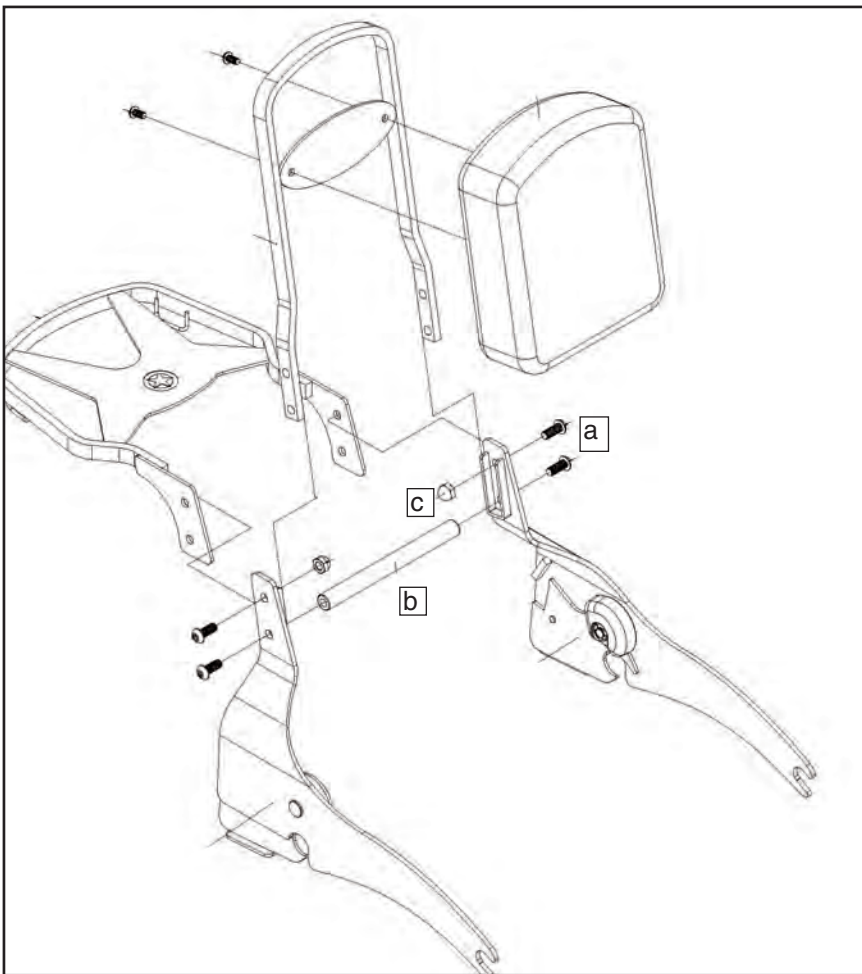



Figure 3

ASSEMBLY OF COMPONENTS

 The Paladin Backrest and Luggage Rack are sold separately. Backrest part no. P9800A; rack part no. P9900.

 Before installing fasteners we recommend you apply a small amount of Loctite® medium strength #243 thread retaining compound (or similar brand) to the threads of the button head screws (a) referenced on page 3 and to the M8 screws used to attach eyebrow. (Page 2, step 2.) **(Thread Lock)**

1. Assemble side plates (1) or (1A) and (2) or (2A) to the Paladin backrest alone or with the Paladin luggage rack. **(5mm Hex Wrench) Figure 3**

2. Use the button head screws (a) and the support stay (b) provided with the backrest and cap nuts (c) provided in bag#529 to complete assembly of the side plates. **(5mm Hex Wrench and Thread Lock) Figure 3**

3. Torque screws (a) and cap nuts (c) to 17 ft/lb). **(Torque Wrench)**

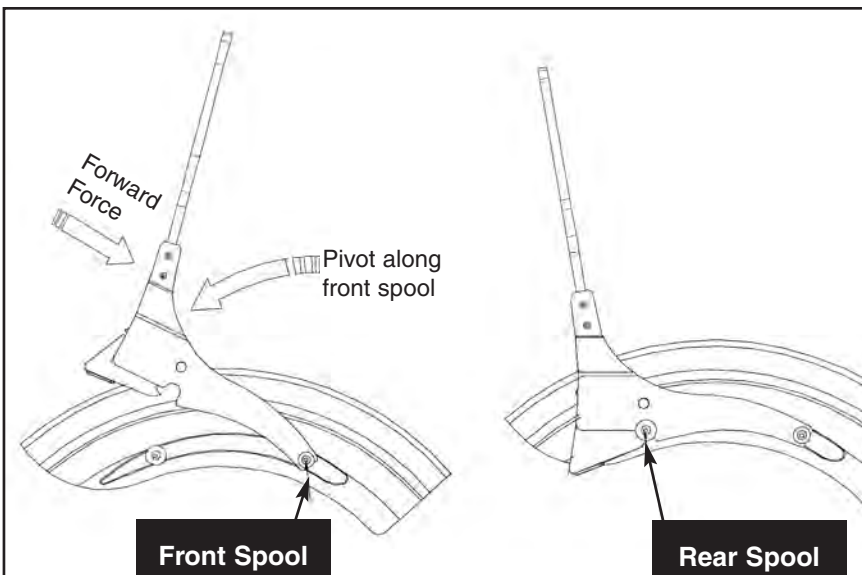

Figure 4

INSTALL ASSEMBLY TO MOTORCYCLE

7. Check that QuickSet™ is unlocked. Install backrest assembly onto motorcycle by first positioning side plates on front spools. With smooth continuous forward force, rotate the backrest assembly downward on to the rear spools while pushing down firmly to engage both side plate latch mechanisms with the rear spools.

Figure 4.

8. Tighten the four M8 x 60 screws to 22 Nm (17 ft/lb) **Torque Wrench, 5 mm Hex Wrench**

9. Make sure to lock the backrest in place before operating the motorcycle.

10. To remove backrest assembly, stand behind vehicle. Unlock and pull up gently on side plate latch mechanisms. Rotate backrest assembly upward and then pull back to disengage front spools.

PATENT No. 6484914

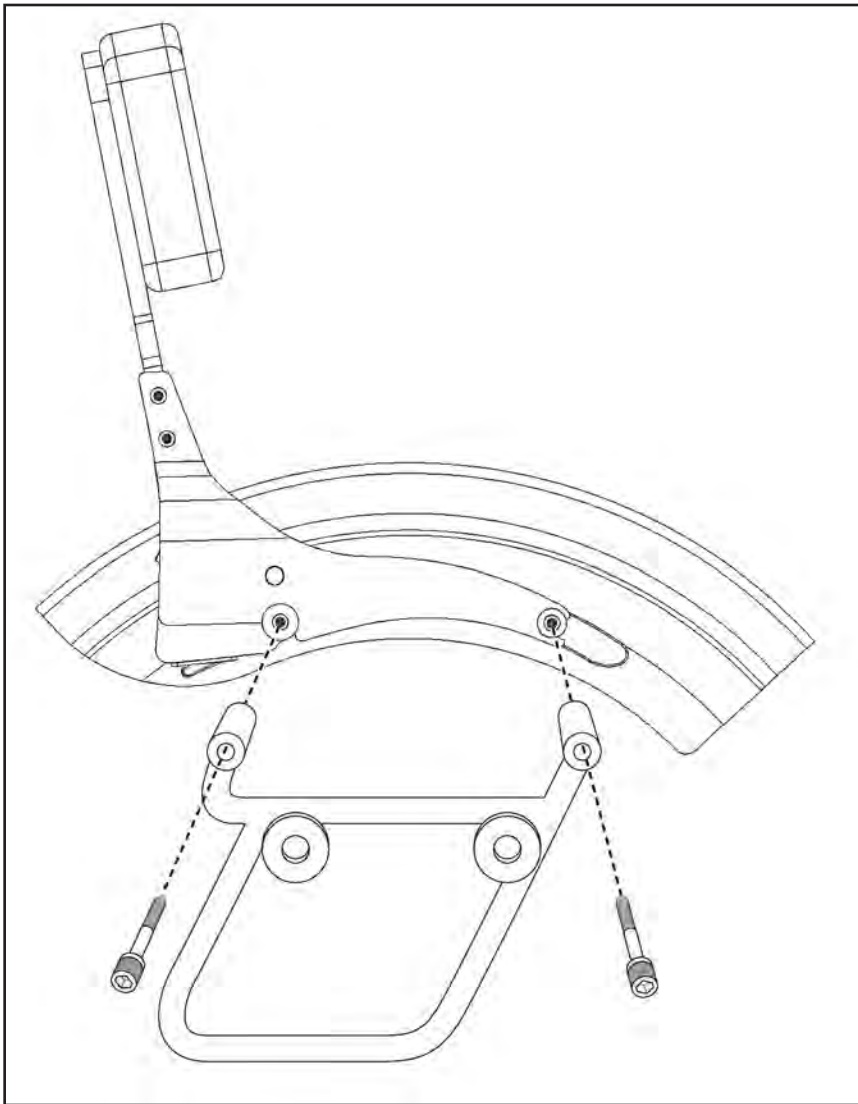



Figure 5

INSTALLING PALADIN KIT WITH CRUISELINER SADDLEBAGS

 For this installation you will need Cruisliner Saddlebag Kit and Supplemental Bag#884. Bag#884 contains four, CS,HS, M8-1.25 X 75mm Stainless Screws. Purchase Bag#884 from your dealer or directly from National Cycle.



Before installing fasteners we recommend you apply a small amount of Loctite® medium strength #243 thread retaining compound (or similar brand) to the threads of the M8 screws used to attach frame to eyebrow. **(Thread Lock)**

1. Refer to page one of this instruction manual and install the eyebrow and spool assembly as instructed.

Rear Screws

2. Remove the *rear* screw from one side.

3. Install the frame bracket using the four M8-1.25 x 75mm screws from Bag #884 and the whizlok nuts contained in this kit. **(6mm Hex Key and 13mm Wrench) Figure 5**

4. Repeat installation on other side.

6. Tighten screws to: M8 = 17 ft/lb.

WARNING

Maximum load for the Luggage Rack is 5 Kg (11 lbs).

When mounting the Backrest assembly, listen for the audible "click" indicating that the latches are in place. Always lock the QuickSet® Side Mount Plate before using your motorcycle. This insures the utmost in safety.

Never ride your motorcycle with loose accessory mounting hardware. Check the hardware for tightness regularly.

Today's motorcycles are built with enough frame rigidity to withstand the moderate loads imposed on them by the foreseeable addition of an accessory. If the accessory(ies) adversely affects your motorcycle's stability, immediately remove the accessory(ies). Do not ride a motorcycle that exhibits unsafe handling traits.

Have experienced service personnel correct any problem before riding with the accessory(ies) installed. For further questions concerning handling problems associated with an accessory(ies), contact your dealer, motorcycle manufacturer, or accessory manufacturer.

MAINTENANCE

The high quality chrome finish of your National Cycle Paladin rack assembly can be maintained with any quality chrome cleaner and or polish.