

Description:	Quantum® Hardcoated Polycarbonate UTV AirFlares™	Model:	Polaris® RZR1000 Round Tube Cage
Part Number:	N40200	Installation Time:	15 min.

Thank you for purchasing a National Cycle product. Read these instructions carefully and thoroughly before beginning work. Dealers, if installing this windshield for a customer, please give them this manual. It contains information needed to properly maintain and use this product.



Attention:
Special notes and cautionary measures which can prevent damage to the accessory or vehicle.



Note:
Tips for facilitation of operation, control and adjustment, as well as maintenance work.

Parts List	Tools Required
------------	----------------

Item	Part No.	Description	Qty.	Notes and Tools
1	20-290585-000	AirFlare, Left	1	
2	20-290599-000	AirFlare, Right	1	
KIT-N40200				
3	44-449370-000	Clamp, Wraparound	4	
4	44-449380-000	Retaining Pin	4	
5	49-490355-000	Washer, Flat, Black	4	
6	55-563131-000	Screw, Phillips, #12 x 1.25,	4	#2 Phillips Screwdriver
7	44-447502-000	Grommet, Rubber	4	
8	77-771152-000	Velcro® Fastener, Hook, .75" x 5.0"	2	Scissors
9	77-771153-000	Velcro® Fastener, Loop, .75" x 5.0"	2	
10	77-771168-000	Velcro® Fastener, Hook, .50" x 9.5"	2	
11	75-771169-000	Velcro® Fastener, Loop, .50" x 9.5"	2	

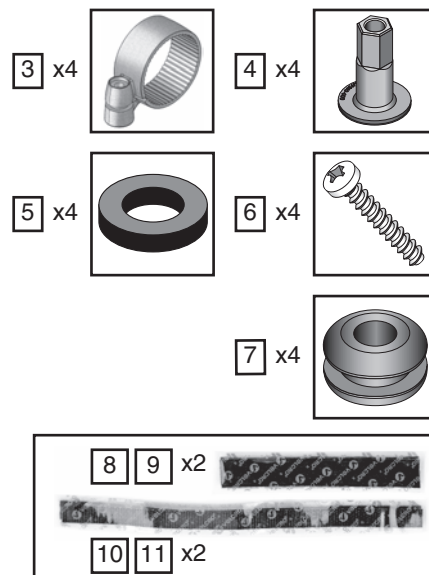
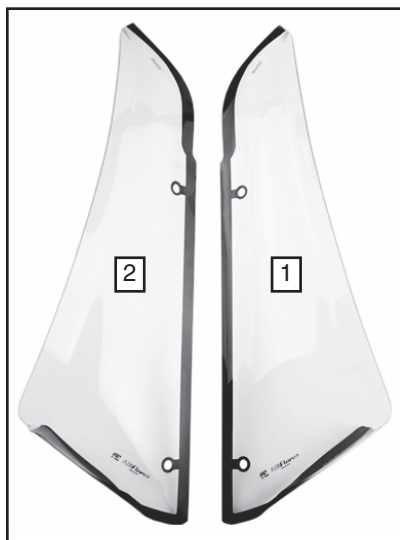

PREPARATION

This Parts Kit has been carefully packed and inspected at the factory. Report any missing part directly to National Cycle Inc. along with the KIT No. and Date marked on the outside of the Parts Kit.

Carefully unpack the windshield, sort the parts, and make sure you have everything required to complete the installation to the vehicle.

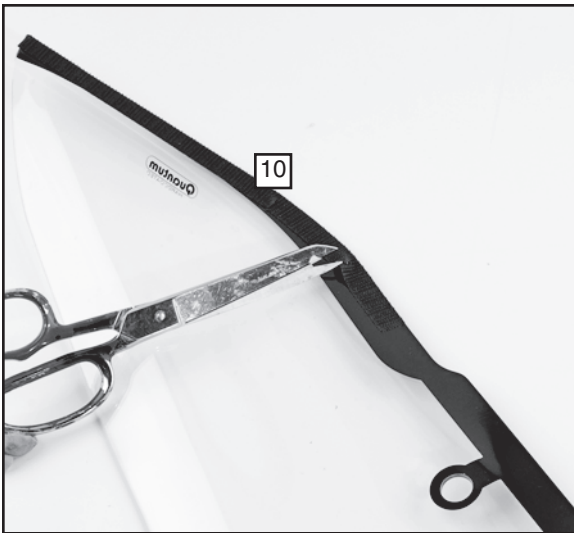

Figure 1



Figure 2

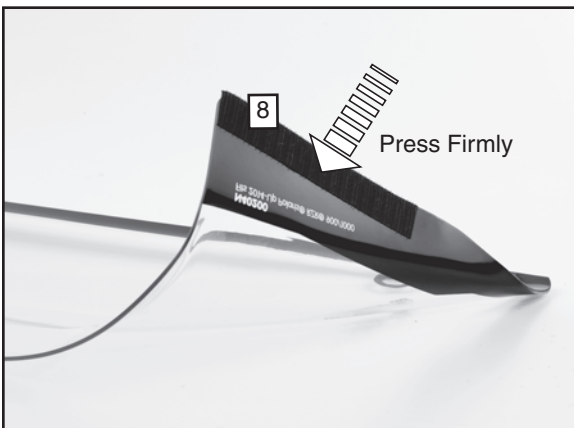

Figure 3

INSTALLATION

Apply Velcro Fasteners to AirFlares



Clean the AirFlares if necessary. Do not use wax or polish.

1. Apply the hook side of .50"x9.5" Velcro Fastener (10) to the **upper inside edge** of clean AirFlare. Clip curves as necessary. Press fastener firmly in place. **(Scissors) Figure 1**

2. Apply the loop side of .50"x9.5" Velcro Fastener (11) onto the hook side. **Do not yet remove backing from loop side.** Clip curves as necessary. **(Scissors) Figure 2**

3. Install one Rubber Grommet (7) into each of the two holes in the AirFlares.

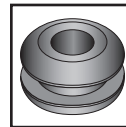

7 x2

4. Apply the hook side of .75"x5.0" Velcro Fastener (8) to the **lower outside edge** of clean AirFlare. Press fastener firmly in place. **Figure 3**

5. Apply the loop side of .75"x5.0" Velcro Fastener (9) onto the hooked piece. the hook side. **Do not yet remove backing from loop side.** Clip curves as necessary.

6. Repeat steps 1-5 on the opposite side AirFlare.

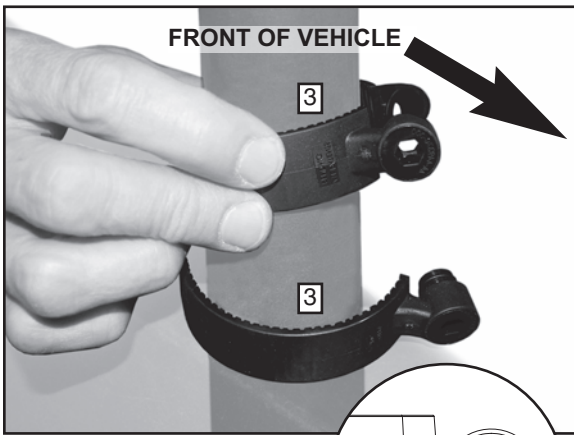

Figure 4

Illustration A

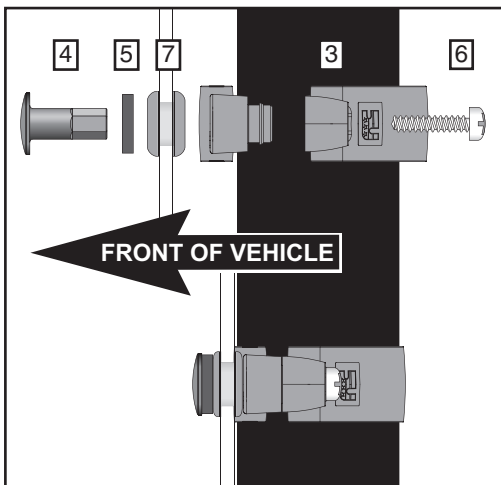
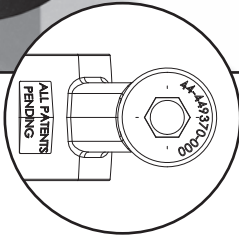

Illustration B



Figure 5

Install Wraparound Clamps

7. Snap two Wraparound Clamps (3) on the left side roll cage bar of the vehicle. Orient the Clamps with the male/female ends toward the outside of the vehicle and with the male ends (with embossed part number) facing toward the front of the vehicle.

Figure 4 and Illustration A

Install Fasteners

8. Position the left AirFlare on the vehicle and align the Wraparound Clamps to the two holes. Loosely install the two Clamps to the Grommets (7) in the AirFlare using:

- Two Retaining Pins (4)
- Two Black Washers (5)
- Two Phillips Screws (6)

Illustration B (Phillips Screwdriver)



Note the matching hex shape of the Retaining Pin and the male end of Wraparound Clamp.

Check Alignment

9. Check the alignment and position of the AirFlare and make sure it is even and symmetrical. **Figure 5**

The lower section of the AirFlare should be touching the side panel of the vehicle.
The top section of the AirFlare should be touching the top roll bar when pressure is applied.

Install AirFlare to Vehicle Cage with Velcro Fastener

12. Remove the protective backing from the Velcro loop material and then press the AirFlare firmly onto the vehicle.

Figure 5

13. Repeat for right side of vehicle.

Final Tightening

14. Securely tighten the Phillips Screws (6) in the four Wraparound Clamps (3). **Figure 6**

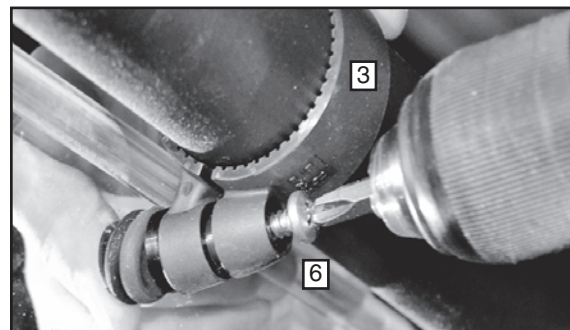

Figure 6



CLEANING AND MAINTENANCE

To clean the screen, wash with a clean soft cloth, plenty of warm water and if necessary, a non-abrasive soap such as dishwashing liquid. Flannel or soft chamois make good cleaning cloths. **Paint, glue residue or grease removal:** Moisten cotton with naphtha or turpentine followed by a wash as above.

National Cycle **Shield Wash™** (N1401-01) makes a good daily cleaner and comes with a handy travel size bottle. Shield Wash is safe for all windshields and helmet visors.

Do not clean polycarbonate in hot sun or high temperatures. Do not clean the screen with glass cleaners.

Do not allow brake fluid, alcohol, or strong solvents to contact the screen.

RAIN REPELLENT

Do not use rain protective products made for glass. We recommend National Cycle's **RainZip®** (N1410-01) to help shed water in rainy weather.

WARNING

CAUTION: The maximum speed for trailering the vehicle with the windshield is 65 MPH minus headwind speed. Always face AirFlare forward (in direction of travel) while carrying on truck or trailer.

CAUTION: Plasticizers from some new vehicle covers or other coverings that are made from PVC may damage plastic products. Do not use a new cover for a few days. Remove it from its package and leave in the sun or other warm location. Use caution when storing your vehicle covered with your windshield or AirFlares installed to avoid gases from becoming trapped under the cover.

Do not clean polycarbonate in hot sun or high temperatures. Do not clean the screen with conventional glass cleaners.

Certain chemicals, generally known as acidic hydrocarbons, are known to cause polycarbonate damage. Do not allow brake fluid, alcohol, or strong solvents to contact the screen.

RAIN REPELLENT

Do not use rain repellent products made for automotive glass. We recommend National Cycle's **RainZip®** (N1410-01) to help shed water in rainy weather.