



INSTALLATION INSTRUCTIONS  
N5521 Hand Deflectors  
for Indian Scout Motorcycles

Thank you for purchasing a National Cycle Accessory.

**Dealers:** If installing this product for a customer please give them this manual. It contains information needed to properly maintain and use this product. Please report all missing parts directly to National Cycle. You will need the date from the package found on the end panel or the back of the package.

**Attention:**



Special notes and cautionary measures which can prevent damage to the accessory or motorcycle.

**Note:**



Tips for facilitation of operation, control and adjustment, as well as maintenance work.

**Parts List for Kit**

<u>INDEX</u>	<u>DESCRIPTION</u>	<u>QTY</u>
1	20-231004-000 Hand Deflector Shield	2
2	37-370900-000 Plate, Outside	2
3	75-762010-000 Washers Neoprene	4
4	42-480000-000 Nut, 1/4-20	4
5	50-530505-000 Screw 1/4 - 20	4
6	37-370905-000 Bracket, Left	1
7	37-370906-000 Bracket, Right	1
8	49-492310-000 Washer, Int. Lock	2

**MAINTENANCE**

To clean the plastic portion of the Deflector, wash with a clean soft cloth, plenty of warm water and if necessary a non-abrasive soap such as dishwashing liquid. Flannel or soft chamois make good cleaning cloths. Paint, glue residue or grease removal: Moisten cotton with naphtha or turpentine followed by a wash as above. Apply a high quality plastic polish. This will leave a protective coating on the material making future cleanings easier.

Maintain the chrome finish with any quality chrome cleaner and / or polish.

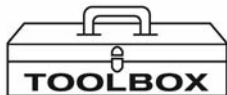

Wrench 14mm  
Wrench 7/16"  
Screwdriver, Flat



Left from right is determined while seated on the motorcycle.

## RIGHT SIDE OF MOTORCYCLE

## LEFT SIDE OF MOTORCYCLE

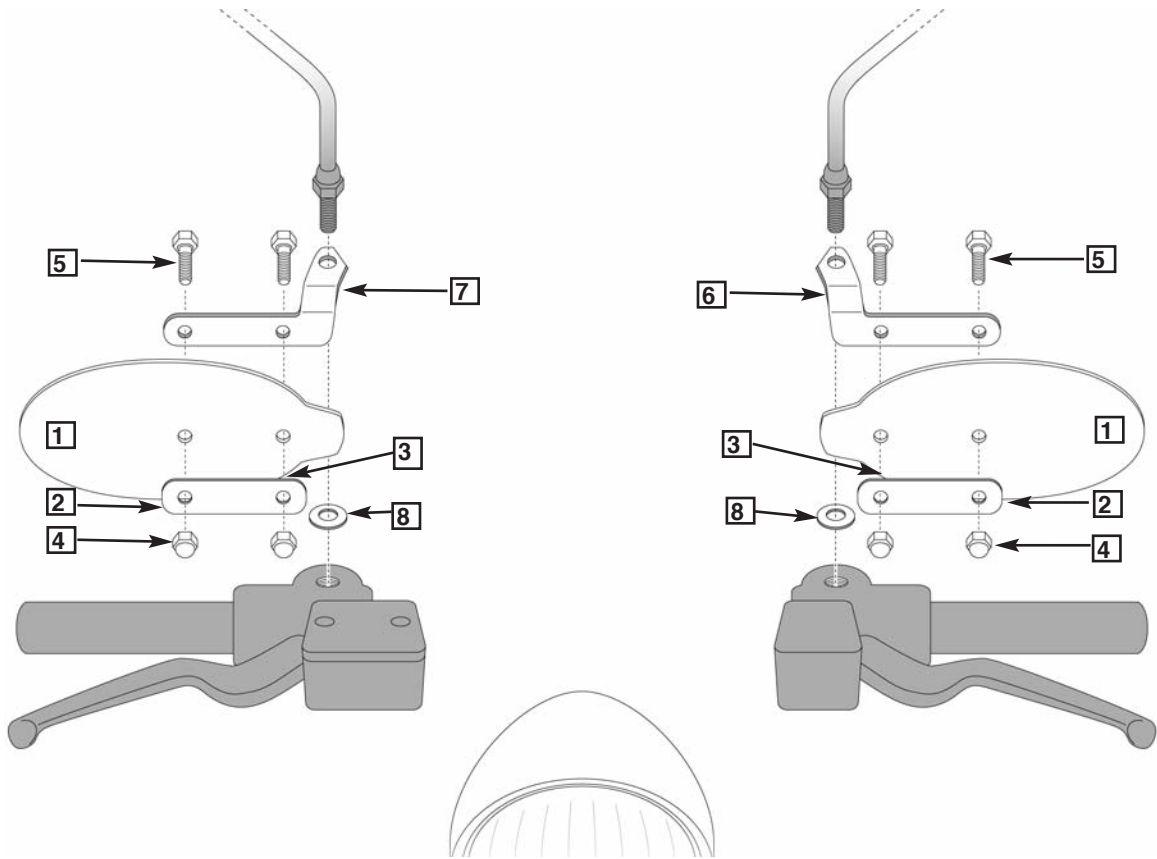

Figure 1

### PREPARATION

Assemble the Hand Deflector plastic to the Right and Left brackets as shown in Figure 1. Insert the Screws from the INSIDE of the Shield. Place a neoprene washer (3) between the outside of the plastic and the outside plate. Place the Outside Plate (2) over the Screws and secure with the Nuts (4). Tighten until snug, do not over tighten. **(7/16" wrench and Screwdriver) Figure 1**

### INSTALLATION

1. Remove the Right Mirror, (Wrench, 14mm).
2. Place a Lock Washer (8) between the mirror mount and the Hand Deflector bracket (7).
3. Install the mirror, check clearance, adjust if necessary.



Check clearance of brake and clutch levers to Hand Deflector plastic.

Check clearance of Hand Deflector to gas tank by turning handlebar to a full lock left and right. If necessary adjust Hand Deflector by rotating bracket until plastic does not contact gas tank.

4. Tighten the mirror nut to 1.8 m-kg (13 ft lbs.) torque.
5. Repeat above procedur for Left side.