

Thank you for purchasing a National Cycle product. Read these instructions carefully and thoroughly before beginning work. Dealers, if installing this product for a customer, please give them this manual upon completion. It contains information needed to properly maintain and use this product.

Description:	Heavy Duty™ Windshield Mount Kit	Model:	2019-Current Royal Enfield INT650
Part Number:	KIT CRE	Installation Time:	20-30 min.

KIT-CRE PARTS LIST

ITEM	PART NO.	DESCRIPTION	QUANTITY
A	37-370249-000	Bracket Mount, Right, Black	1
B	37-370248-000	Bracket Mount, Left, Black	1
C	37-370250-000	Fork Clamp, 41mm, Black	2
BAG#1358			
D	34-365007-000	Bolt Plate, Black	2
E	42-433020-000	Self-Locking Whiz Nut, M6-1.00, Zinc	4
F	51-516317-000	Cap Screw, M6x16 Stainless	8
G	75-764053-000	Clamp Spacer, Neoprene	4

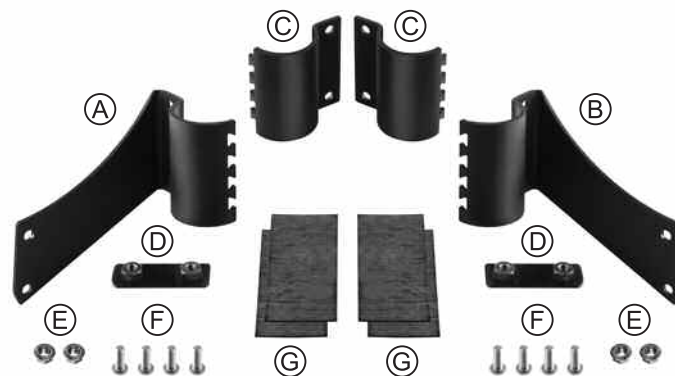

"Right" and "Left" are designated as the rider sits on the bike.

TOOLS REQUIRED FOR ASSEMBLY

4mm Allen Wrench
10mm Box Wrench



ATTENTION: Special notes and cautionary measures which can prevent damage to the accessory or vehicle.



NOTE: Tips for facilitation of operation, control and adjustment, as well as maintenance work.

PREPARATION

Carefully unpack your new accessory, sort the parts, and make sure you have everything required to complete the assembly.



Figure 1

STEP 1: PREPARATION

Figure 1

Park your bike on its sidestand with plenty of room to work around the front end.

Sort the pieces in the Kit and BAG#1358 and make sure everything is in order.

Remove the adhesive backing from the four Neoprene Clamp Spacers (G) and apply them to the inside of the Right and Left Bracket Mounts (A, B) and the two Fork Clamps (C).

STEP 2: MOUNT INSTALLATION

Figure 2

Beginning on the right side of the bike, identify the Right Bracket Mount (A). The National Cycle logo will face outward with the Bracket's straight edge at the bottom and the mounting half on the inside.

Figure 3

Place the Right Bracket Mount over the fork tube and inside of the cables and wiring.

Figure 4

Rotate the Right Bracket Mount (A) so that the bracket section is facing forward.

Figure 5

Take one of the Fork Clamps (C) and join the teeth with those on the Right Bracket Mount (A).

Figure 6

Mate the drilled clamp section of the Fork Clamp (C) to the drilled clamp section of the Right Bracket Mount (A).



Figure 2

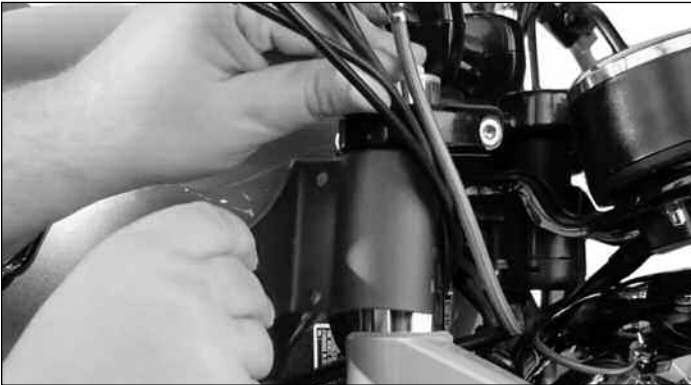

Figure 3



Figure 4



Figure 5

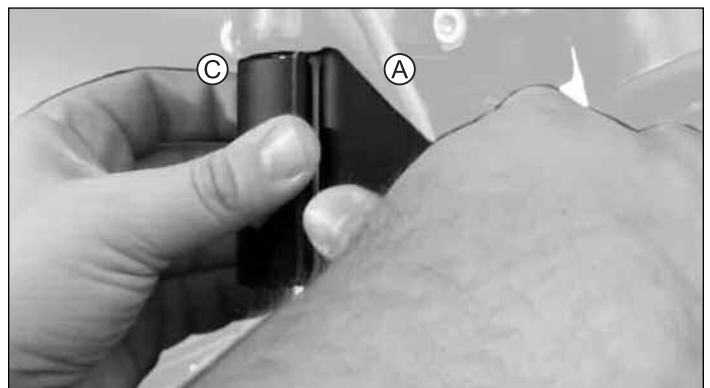

Figure 6

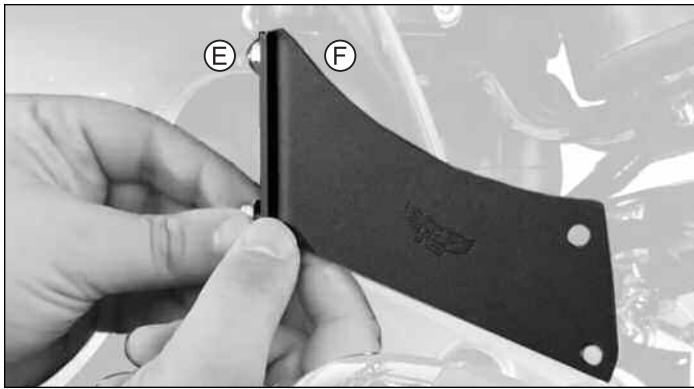

Figure 7

STEP 2: MOUNT INSTALLATION; CONT'D

Figures 7

Insert two M6x16 Cap Screws (F) into the front of the Right Bracket Mount and secure them at the rear of the Fork Clamp with two M6-1.00 Self-Locking Whiz Nuts (E).

Make sure the Right Bracket Mount is facing straight forward. Use a 10mm Box Wrench and a 4mm Allen Wrench to tighten the fasteners securely.

Figure 8

The installed right side mounts should appear as shown.



Figure 8



Repeat the procedure outlined in Figures 2-8 on the left side of the motorcycle.

STEP 3: WINDSHIELD INSTALLATION



Whether you install an N2220 Custom Heavy Duty™, an N2221 Low Boy Heavy Duty™ or an N2290 Ranger Heavy Duty®, the installation procedure is the same.

Figure 9-10

With the Windshield's right-side bracket on the inside of the Right Bracket Mounts (A), place one Bolt Plate (D) over the inside of the Windshield's bracket.



Figure 9

Figure 11

Insert two M6x16 Cap Screws (F) through the outside of the Right Bracket Mount, through the windshield's bracket, and into the Bolt Plate (D).

Using a 4mm Allen Wrench, tighten the Cap Screws enough to hold the Windshield in place. Final alignment, adjustment and tightening will come later.



Repeat the procedure outlined in Figures 9-11 on the left side of the motorcycle.



Figure 10

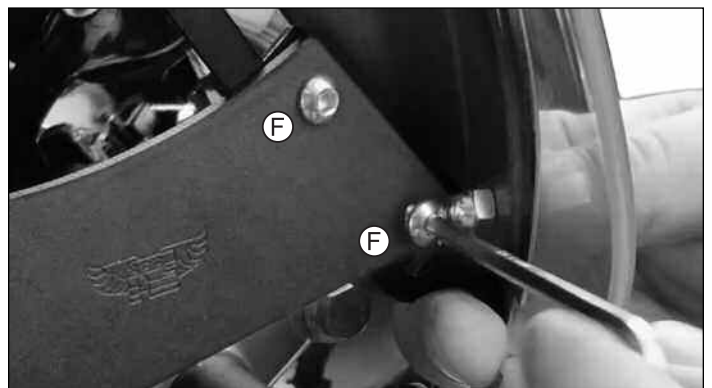

Figure 11



Figure 12

STEP 3: WINDSHIELD INSTALLATION; CONT'D

Figures 12

After the four M6x16 Cap Screws (F) have been inserted through the Right and Left Bracket Mounts (A, B) and into the Bolt Plates (D), check the Windshield's position.

It will need to be mounted high enough to clear the bike's turn signals, and it should be horizontally and evenly level and exactly centered over the headlight.

Make any final adjustments to the Right/Left Bracket mounts and/or the Windshield's bracket positioning.

With a 4mm Allen Wrench, tighten all mounting hardware firmly and securely.

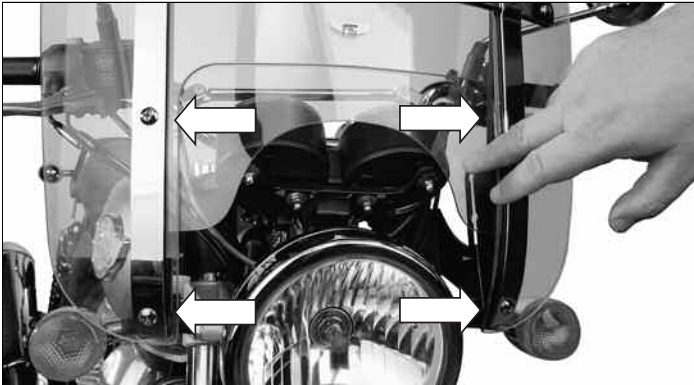

Figure 13

Figures 13

Your Heavy Duty™ Windshield features an adjustable center window.

You can loosen the four screws indicated to move the center window up or down. Most riders prefer to have it as close to the headlight as possible.



Make sure to retighten these screws when you are done.

The installation is now complete. Double-check all fasteners for tightness before hitting the road.

Test ride for function and performance, and enjoy your new Heavy Duty™ Windshield!

⚠ WARNING

Never ride your motorcycle with loose accessory mounting hardware. Check the hardware for tightness regularly.

Today's motorcycles are built to withstand the moderate loads imposed on them by the foreseeable addition of an accessory(ies). If an accessory(ies) adversely affects your motorcycle's stability, immediately remove the accessory(ies). Do not ride a motorcycle that exhibits unsafe handling traits.

Have experienced service personnel correct any problem before riding with the accessory(ies) installed. For further questions concerning handling problems associated with an accessory(ies), contact your dealer, motorcycle manufacturer, or accessory manufacturer.

Sunlight reflected off the inside curvature of the windscreen can, at certain times of day, cause extreme heat buildup on the motorcycles instruments and possibly even melt them. Exercise care in parking to avoid this. Park your motorcycle facing the sun or place an opaque object over this area.

