



national cycle

plexistar 2™ / AIRHAWK™

OWNER'S MANUAL AND ASSEMBLY INSTRUCTIONS

DEALERS: If installing the PLEXISTAR 2 or AIRHAWK for a customer please give him this manual. It contains information needed to properly maintain and use this product.

This manual is designed for complete product knowledge; parts identification, installation, adjustment, precautions, maintenance, and replacement parts. Please take the time to become familiar with your PLEXISTAR 2 or AIRHAWK to obtain the best results in use.

INSTALL UPRIGHTS AND LOWER "L" BRACKETS

1. Open all bags and group parts together as upper and lower assemblies as shown in the diagrams.

THE CIRCLED NUMBER IS THE QUANTITY.

UPPER QUICK SET™ HARDWARE

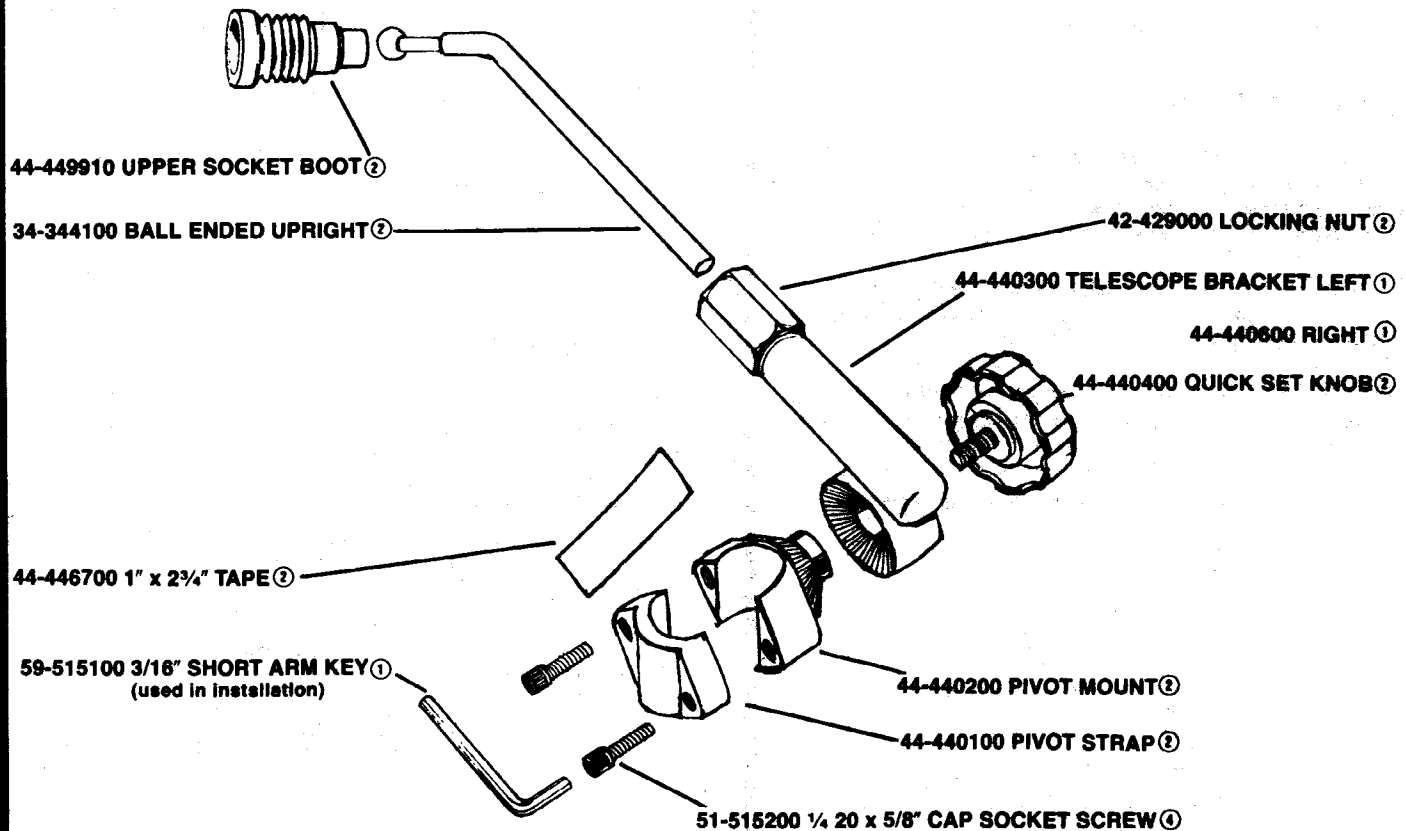

LOWER QUICK SET™ HARDWARE

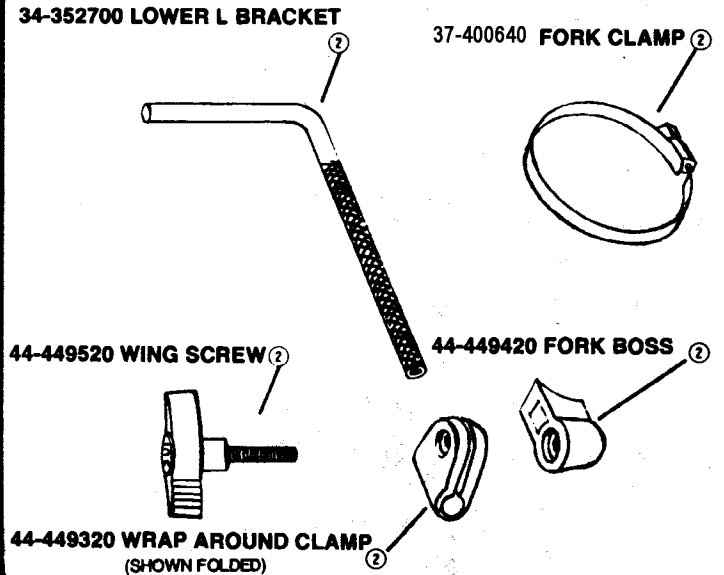

2. Use a padded surface or some other fixture to support the PLEXISTAR 2 or AIRHAWK. Firmly grab the lower leg section and insert a lower "L" bracket with a twisting motion. Do both sides. If the fairing is colder than 65° F, it might be necessary to WARM the swivel and socket points with a hair dryer. DO NOT USE LUBRICANTS (EXCEPT) SALIVA OR WATER) ON ANY PART OF THE SCREEN OR HARDWARE!

WORK IT IN WITH A BACK & FORTH TWISTING MOTION

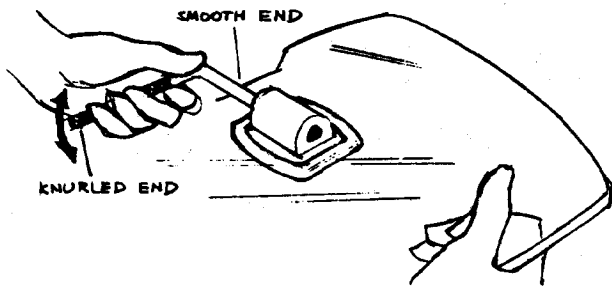

3. Slide a upper socket boot over each upright. Support fairing on a non abrasive surface and push in an upright on each upper socket as shown. NO LUBRICANTS! except SALIVA or WATER.

4. Slide the appropriate left and right telescope bracket onto the upright.

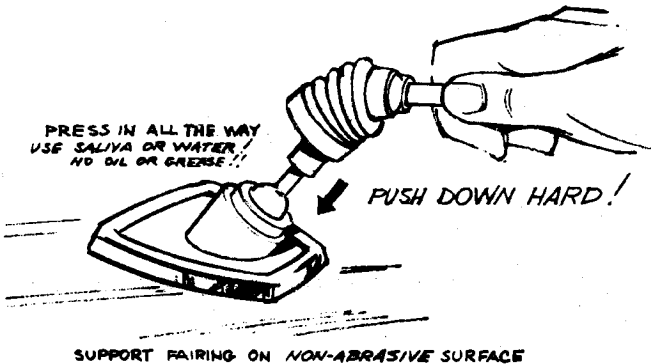

POSITION FAIRING ON MOTORCYCLE

5. Put motorcycle on center stand. Straddle front wheel and spring the PLEXISTAR 2 or AIRHAWK legs apart by pulling back on handlebar portions. Now slide fairing on bike. Be careful not to snag any control cables or loose wires. If necessary, bend the control cable loops out of the way. Legs should be behind turnsignals.

PLEXISTAR 2 OWNERS: PLEXISTAR 2 does not rest on headlight or headlight rim. Clutch and brake level ends should be, as well as instrument pod, somewhat close but preferable not touching fairing*.

AIRHAWK OWNERS: AIRHAWK rests on headlight rim. Clutch and brake lever ends should be, as well as instrument pod, somewhat close but preferable not touching fairing*.

* If contact occurs, a protective bumper should be but in place.

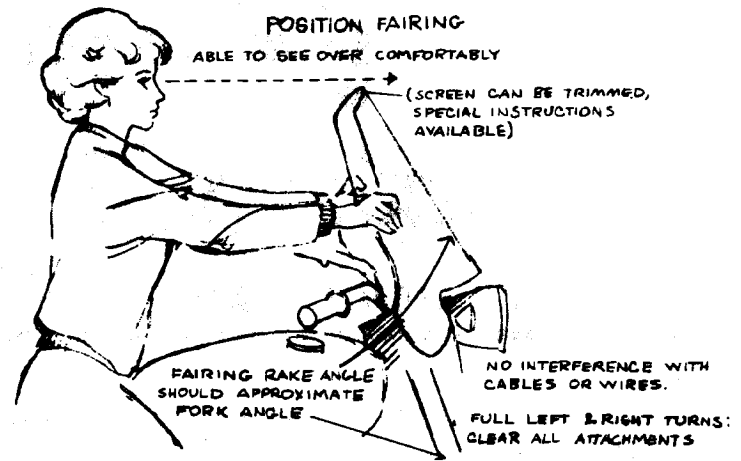
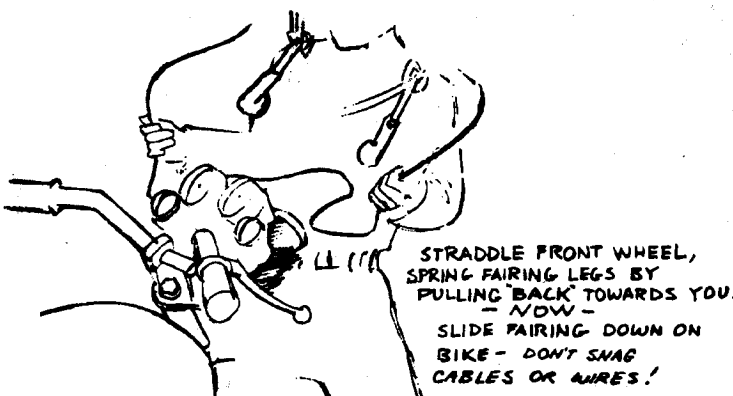

DETERMINE LOCATION OF PIVOT MOUNT ON HANDLEBAR

6. Determine where to mount pivot mounts by positioning telescope brackets to handlebars. Try to achieve as closely as possible:

A. MINIMIZE upright extension from telescope bracket. Slide handlebar pivot assembly up the bar to reduce this.

B. Have the upright/telescope bracket combination at about a 45° angle or even more horizontal with respect to the road. More vertical angles are slightly less rigid.

7. Once position has been determined mark bar with grease pencil or masking tape. Remove fairing from motorcycle for safe keeping or let rest back against instrument cluster and handlebars.

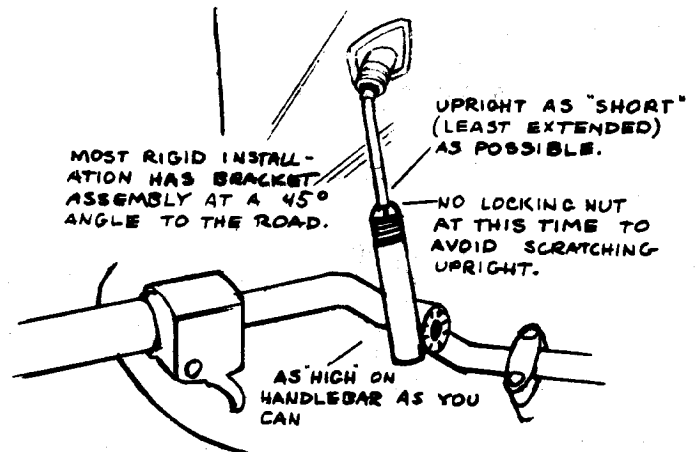

INSTALL PIVOT MOUNTS

8. Place 1 piece of double stick tape around handlebar in location of pivot mount. The tape is necessary to avoid rotational slippage on some bikes. Install the pivot mounts to your handlebars by attaching the pivot mount to pivot strap with the 1/4 20 bolts until snug, BUT NOT TIGHT. Use wrench supplied in hardware kit. Be sure both sides are symmetrical.

PLACE PIVOT MOUNT AS CLOSE TO UPPER BEND ON HANDLEBAR AS PRACTICAL.

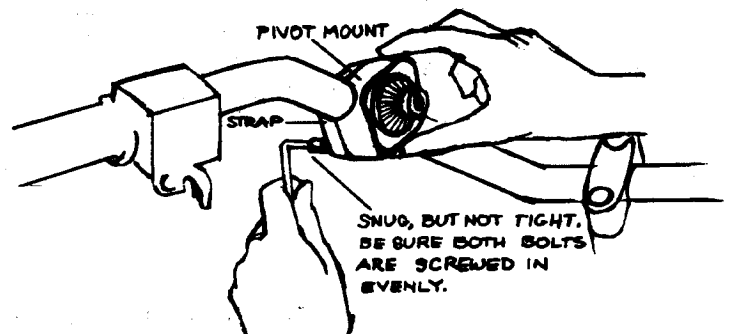

9. Remove telescope brackets now and loosely screw on locking nuts and replace telescope brackets on uprights.

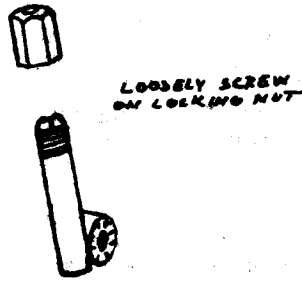

10. Reposition PLEXISTAR 2 or AIRHAWK on motorcycle. Engage telescope bracket with pivot mount and secure with QuickSet knob. **HAND TIGHTEN LOCKING NUTS UNTIL FINAL ADJUSTMENT IS COMPLETE.**

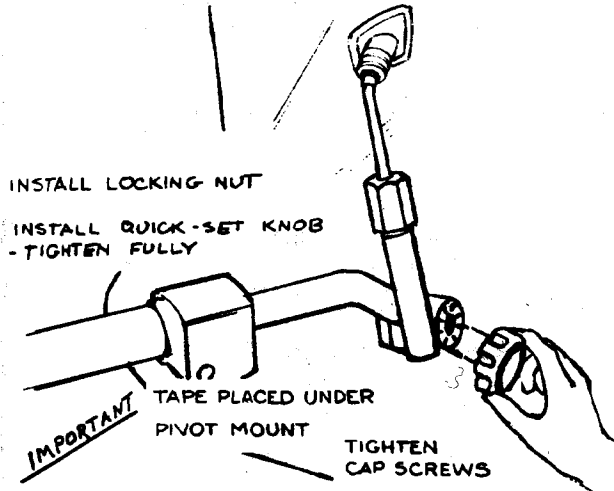

LOWER HARDWARE

11. Examine lower bracket area and select best location for fork boss.
 A & C Offer easiest removeability but sometimes interfere with tank at full fork lock.
 B is good but usually is prohibited by headlight shell interference.
 C & D Are usually the best locations.
 NOTE: The lower "L" bracket can be swiveled in any direction (up, down, to the front of fork) necessary for proper clearance.
 Where the lower leg area of the fairing falls in relation to the fork tube will also vary. Some installations will require fairing leg to be even with, or possibly in front of fork leg.

AIRHAWK OWNERS: In most cases the lower leg area of the fairing will fall in front of, or along side of the fork.
 Select the best fork boss position for your motorcycle.

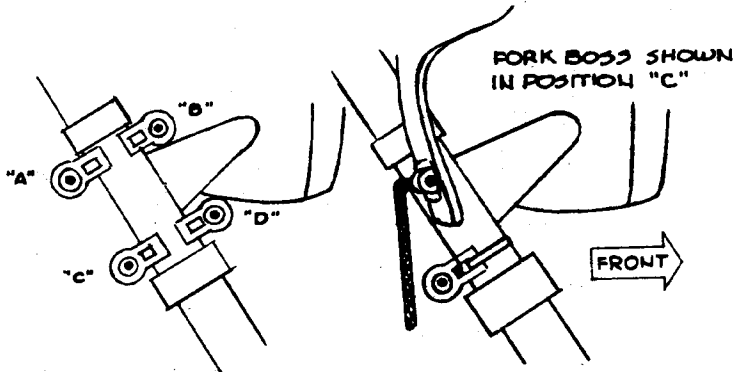

POSSIBLE FORK BOSS POSITIONS

NOTE: ANGLED "L" BRACKET SHOWN IN ONE OF MANY POSSIBLE POSITIONS. SOME INSTALLATIONS WILL REQUIRE FAIRING LEG TO BE EVEN WITH, OR POSSIBLY IN FRONT OF, FORK LEG.

12. Thread fork clamp thru fork boss and **TIGHTEN LOOSELY** around fork. Cosmetically it is preferable to have the screw of the fork clamp facing toward rider on inside of fork leg. After final adjustment cut off excess strap with diagonal cutters.

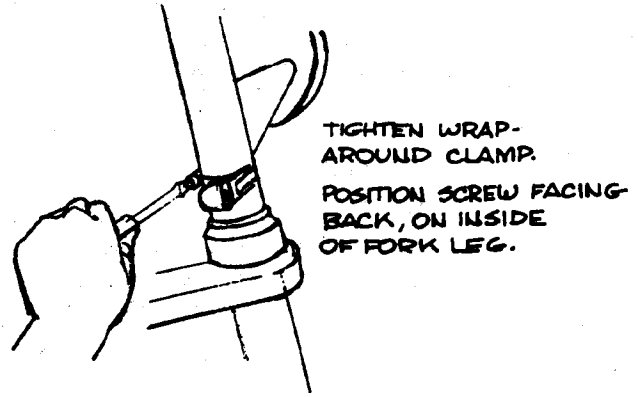

13. Place wrap-around clamp on knurled area of "L" bracket, push wing screw through and then insert and tighten into fork boss. **TIGHTEN FORK CLAMPS AFTER wing screw is tight.**

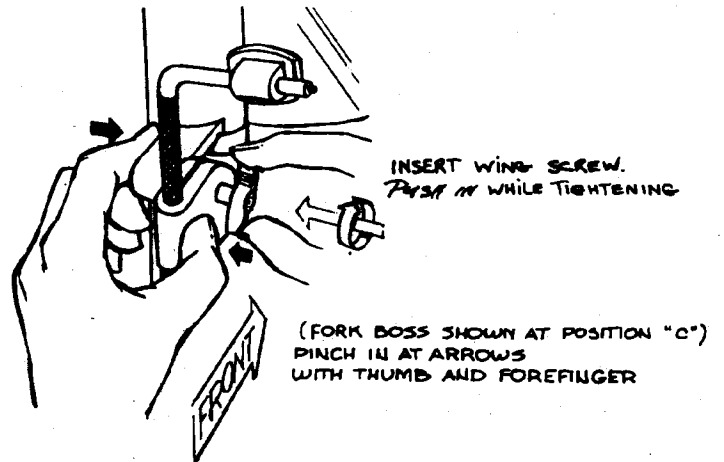

FINAL ADJUSTMENT

14. Sit on seat in normal riding position with motorcycle off center stand. Grip top of PLEXISTAR 2 or AIRHAWK and position screen to achieve the following:
 A. No interference with cables, full turn left and right clearance for fork lock and gas tank, turn signal, rearview mirror and/or radiator, crashguard clearance.
 B. Proper top height; PLEXISTAR 2 and AIRHAWK are sport size fairings proportioned lower than our full size PLEXIFAIRING 3. In the event you cannot see over the top of the screen, you may want to trim the fairing. Refer to page 4 TRIMMING INSTRUCTIONS.
 C. Rake angle should approximate fork angle. AIRHAWK lowers are designed to curve forward of fork.

TIGHTEN FULLY: Locking nuts (wrap with some soft paper and quickset knob or cloth to avoid scuffs) and fork clamps. Also be sure hex bolts of pivot mounts are fully tightened. Refer to page four of this manual for additional information.

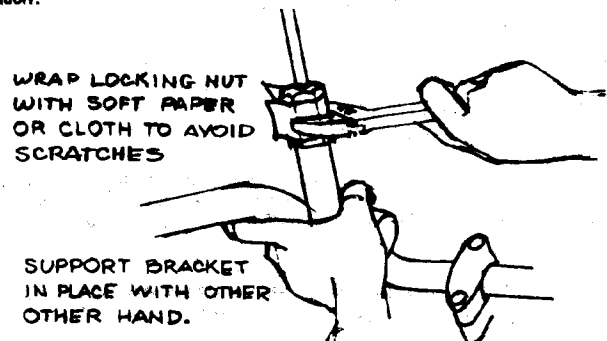

REMOVAL

To remove the windscreen, loosen the two Wing Screws to release the lower fairing mounts. On the handlebars, spin the Quick Set Knobs and release the Telescope Brackets. Now, lift off. A "no tools" removal in less than 30 seconds. Only the Pivot Mount and lower Fork Boss stay on your bike, in alignment and ready for fast, "no tools" re-installation. The ball sockets are not designed as the removability feature and should not be used repeatedly. Uprights with Telescope Brackets and lower L Brackets can remain on the screen. Store the lower Wrap Around Clamp, Wing Screw and Knob with the fairing.

MAINTENANCE

To clean the screen, wash with a clean soft cloth, plenty of warm water and, if necessary, a non-abrasive soap such as dishwashing liquid. Flannel or charmois make good cleaning cloths. Terry cloth is not recommended.

Apply a high quality plastic polish, such as McGuir's Mirror-Glaze MGH-17 or Novus #2, to the clean screen. This will leave a protective coating on the screen making future cleanings easier. Automotive polish or paste wax will also work, but should be tested on a lower inside corner, below the mounts, to be sure it does not damage the material.

DO NOT CLEAN acrylic screens with glass cleaners. The solvent action of the alcohol in the glass cleaner will destroy the acrylic. Do not allow brake fluid, alcohol, or strong solvents to contact the screen or mounting receptacles. Permanent damage will result!

BUFFING

To remove scratches use a very soft clean cloth and a fine grade buffing compound. Jewelers rouge or McGuir's Mirror-Glaze MGH-10 are best for this type of buffing. We recommend hand buffing, but very light pressure with an electric buffer will speed work on deep scratches.

Keep moving across the scratch while buffing. Try not to concentrate on a small area or you will distort the windscreen's optics.

Follow the cleaning instructions above after buffing to keep your screen clean and scratch free.

TRIMMING

All National Cycle accessory and replacement windscreens are top quality wind protection devices. Proper care can help these windscreens give many years of motorcycling enjoyment.

Because each rider has their own combination of physical height and/or motorcycle accessories, trimming may become necessary for the best installation. National Cycle products are made from either acrylic or polycarbonate and can easily be trimmed if a few simple procedures are followed. I'm sorry, we cannot be responsible for damage to the product which occurs during trimming.

NOTE: Use of a jig saw or sabre saw is not recommended!

If the fairing is to be shortened from the top, remember to choose the new height while seated on the motorcycle (both wheels on the ground), with it normally loaded. In all cases you should be able to see over the top of the screen at least by stretching, in case the screen should become opaque because of rain or dirt.

Too much should not be taken off the top as this will affect how far the air shoots off the top of the screen. The rake angle of the screen, which is adjustable in most applications, will also affect how the air comes off the screen.

Mark the line to be cut with a crayon or china marker; these can be easily washed off. A ruler or piece of paper can be used as a guide to duplicate the original shape.

An effective way to secure a Plexifairing or Plexistar is to stand it on the floor and grip it with your knees while seated in a chair. This leaves both hands free for filing or sanding.

The trimming should be done by sanding or filing with a coarse, 60-80 grit file. Since shudders, jolts, and sudden shocks can promote cracking, a smooth continuous motion should be used. A flat belt sander will remove material quickly, but keep the sander moving back and forth for a smooth edge.

If a large amount of trimming is required, a band saw can be used safely. Protect the screen with masking tape before cutting. The blade should have about ten teeth per inch. A hack saw will also work well; be careful not to let it bind in the cut.

Once the desired shape is found, use the coarse file or sandpaper to round the edges. Any scratches that result from handling can be removed. Refer to the Maintenance instructions above.

PLEXIFAIRING 3", PLEXISTAR 2", AIRHAWK™, MIRAGE™, DEFLECTOR SCREEN™, STREET SHIELD™, and other National Cycle wind protection products are covered by one or more of the following patent numbers: 4489973, 4379684, 4082345, 4183888.

WARNINGS

National Cycle windshields and fairings are designed to provide wind protection and increased riding comfort, but not protection in the event of a collision with another vehicle, the road, birds, or any other object.

Our products utilize certain features, patented and otherwise, that may minimize injury in certain accidents, but the possibility of injury exists if the screen is broken or if impacted by an object.

The acrylic sheet that is used in our Plexistar 2™, Plexifairing 3™, Airhawk™, and Airhawk GT™ is almost 30 times more impact-resistant than glass. If it is subject to impact beyond its resistance, it breaks into comparatively large pieces and, normally, does not shatter into small slivers.

Most of our applications are offered in a polycarbonate version which has a higher impact resistance and may prove safer in some accidents. Contact your local dealer for more information on the Plexifairing 3LX™

All of our products are made in conformance and exceed the requirements of D.O.T. SS205, Z26.1, classifications AS6 and AS7, which covers all safety glazing for motorcycle application.

Never ride your motorcycle with loose windshield mounting hardware. Check the hardware for tightness regularly.

Today's motorcycles are built with enough frame rigidity to withstand the moderate loads imposed on them by the foreseeable addition of a fork mounted fairing.

If the addition of an accessory(ies) adversely affects your motorcycle's stability, immediately remove the accessory(ies). **Do not ride a motorcycle that exhibits unsafe handling traits.** Have experienced service personnel correct any problem before riding with the accessory(ies) installed. For further questions concerning handling problems associated with an accessory(ies), contact your dealer, motorcycle manufacturer, or accessory manufacturer.

Sunlight reflected off the inside curvature of the fairing can, at certain times of the day, cause extreme heat buildup on the motorcycle's instruments and possibly even melt them. Exercise care in parking to avoid this. Park facing the sun or place an opaque object over this area.

REPLACEMENT PARTS

All National Cycle parts and accessories can be purchased or ordered through your dealer. If direct order is necessary, a \$6.00 shipping and handling charge must be added. Send check or money order with order to the address below. Illinois residents please add 7.75% Cook County sales tax.

HEADLIGHT TRIM

Because the Plexistar 2 does not contact the headlight, the trim is not necessary. It is available as an optional item. 44-449700 Trim \$9.95

REPLACEMENT HARDWARE

Orders can be placed by bag or complete kit. Please buy from your local dealer. He's there to serve you. Hardware available for non-tubular bars. Complete hardware kit OO for 7/8" Bars \$64.95

Complete hardware kit AG for 1" Bars \$69.95

Bag No. 49

QUANTITY	DESCRIPTION	PART NO.	BAG COST
2	FORK BOSS	44-449420	Complete
2	WRAP AROUND CLAMP	44-449320	
2	WING SCREW	44-449520	Bag Cost
2	FORK CLAMP	37-400600	\$21.50
2	L BRACKET	34-352700	

BAG NO. 50

QUANTITY	DESCRIPTION	PART NO.	BAG COST
2	UPPER SOCKET BOOT	44-449910	Complete
2	LOCKING NUT	42-429000	Bag Cost
2	BALL ENDED UPRIGHT	34-344100	\$19.50

BAG NO. 51

QUANTITY	DESCRIPTION	PART NO.	BAG COST
2	PIVOT STRAP	44-440100	Complete
2	PIVOT MOUNT	44-440200	
1	3/16 SHORT ARM KEY	59-515100	Bag Cost
4	1/4" x 5/8" HEX CAP	51-515200	\$29.95
2	DOUBLE STICK TAPE	44-446700	

BAG NO. 77

QUANTITY	DESCRIPTION	PART NO.	BAG COST
2	PIVOT STRAP	44-440110	Complete
2	PIVOT MOUNT	44-440210	
1	3/16 SHORT ARM KEY	59-515100	Bag Cost
4	1/4" x 5/8" HEX CAP	51-515200	\$29.95
2	SOCKET SCREW		
2	DOUBLE STICK TAPE	44-446700	

BAG NO. 52

QUANTITY	DESCRIPTION	PART NO.	BAG COST
1	TELESCOPE BRACKET LEFT	44-440300	Complete
1	TELESCOPE BRACKET RIGHT	44-440600	Bag Cost
2	QUICK SET KNOB	44-440400	\$19.95

National Cycle, Inc
PO Box 158
Maywood, IL 60153

708-343-0400 / F: 708/343-0625
info@nationalcycle.com