

Thank you for purchasing a National Cycle product. Read these instructions carefully and thoroughly before beginning work. Dealers, if installing this windscreen for a customer, please give them this manual. It contains information needed to properly maintain and use this product.

Attention



Special notes and cautionary measures which can prevent damage to the accessory or motorcycle.

Note



Tips for facilitation of operation, control and adjustment, as well as maintenance.

Parts List				Notes and Tools
Item	Part Number	Description	Qty.	
1	24083	Street Shield, Screen	1	Screen with Mount Points Attached, No Kit
	Kit-N25000	Complete Mount Kit	1	Mount Kit Only
2	34-343561-000	Upper 3/8" Rod, Ball End	2	Loose in Mount Kit
3	34-343560-000	Lower 5/16" Rod, Ball End	2	Loose in Mount Kit
	Bag #135		1	
4	37-410110-000	7/8" (22mm) U-Clamps, Black	2	Measure the Handlebar, Select the Correct Size U-Clamp
5	37-410210-000	1" (25mm) U-Clamps, Black	2	
6	52-521010-000	Eyebolt	2	
7	49-496110-000	Cup Spacer	2	
8	49-492310-000	Internal Washer	2	
9	49-493110-000	Bevel Washer	4	
10	42-432010-000	Nut, Whizlok	2	9/16" Box Wrench or Adjustable Wrench
	Bag #1145			
11	37-400640-000	Fork Clamp, SS #24	2	Flat Blade Screw Driver
12	42-451105-000	Locking Nut, Lower	2	5/8" Box Wrench or Adjustable Wrench, Small Cloth for Protection
13	44-449450-000	Fork Boss	2	
14	44-449455-000	Collet Tube, Left	1	
15	44-449456-000	Collet Tube, Right	1	
16	44-449460-000	Wing Screw	2	

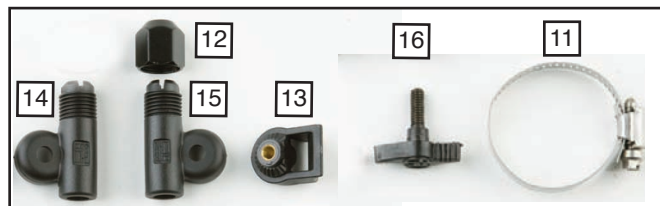
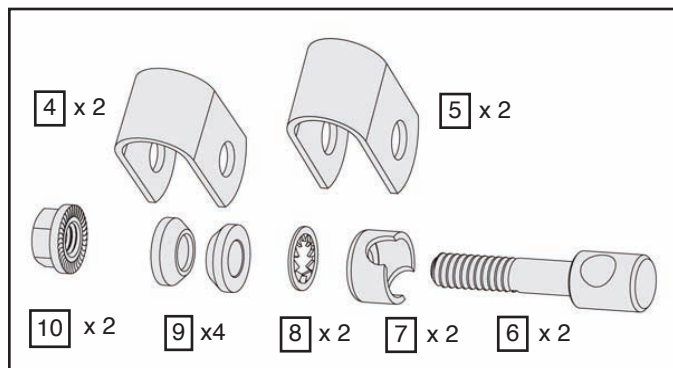
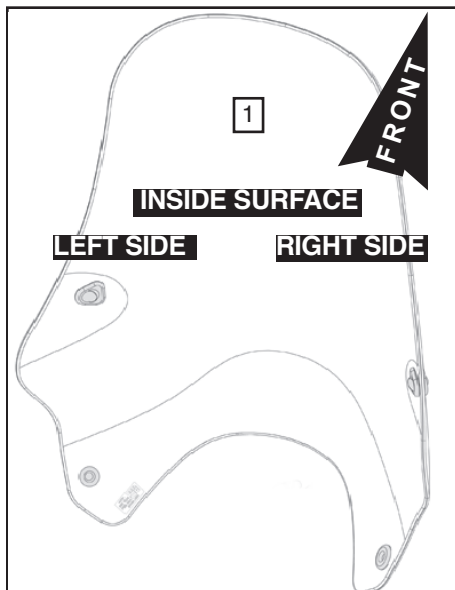

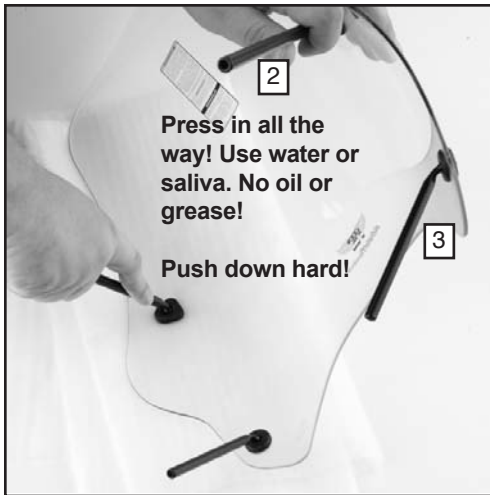

Figure 1

PREPARATION

1. Position motorcycle securely on its side stand.

INSTALLATION

INSTALL UPPER AND LOWER RODS TO SHIELD

1. Install the Upper Rods (2) and Lower Rods (3) into Ball Sockets. Place shield face down on smooth, none scratching, well supported surface. Wet the upright ball with saliva; **do not** use oil, grease, or silicone as lubricant. Push upright ball into socket until seated, it will “pop” into place. Do this at all four sockets. **Figure 1**

U-CLAMP ASSEMBLY

2. Size your handlebars. Select the 7/8” (22mm) or the 1” (25mm) U-Clamps from Bag#135.

3. Hold shield to motorcycle and select the best location around a vertical section of the handlebar to mount the U-Clamps. **Figure 2c**

4. Put an Indented Cup Spacer (7) and an Internal Lock Washer (8) on each of the Eyebolts (6). Slip Eyebolts through the U-Clamps. At the same time, insert two Bevel Washers (9) (bevels facing each other) inside each U-Clamp so that the Eyebolt passes through them. **Figure 2a and 2b**

5. Align the Cup Spacer (7) indentations with the “eyes” of the Eyebolts (6). With the U-Clamps aligned evenly on each side of the handlebars, slide the Uprights of the assembled screen through the Eyebolts. **Figure 2a and 2b**

6. Carefully align the screen so that it sits slightly above and not directly on the headlight. Now **loosely install** WhizLok Nuts (10) onto the threaded portion of the Eyebolts. (**9/16” Box Wrench**)

ADJUSTABLE- SELECT BEST LOCATION

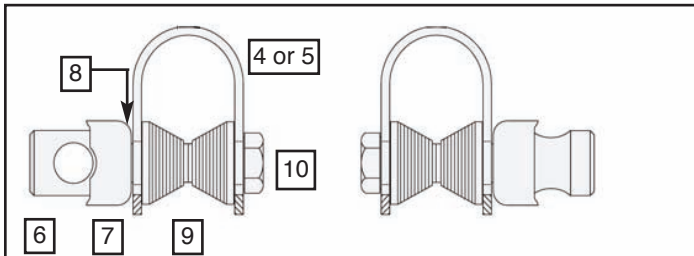

Figure 2a

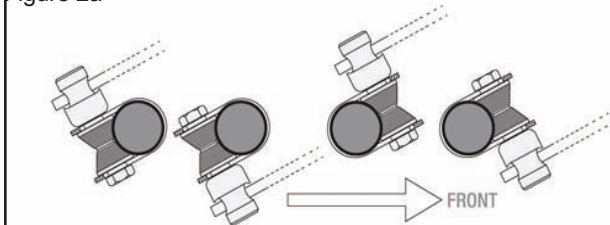

Figure 2b

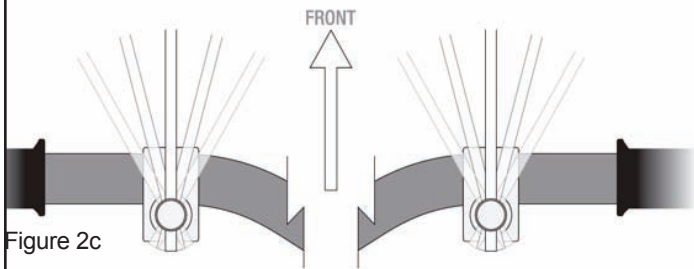

Figure 2c

Figure 2

INSTALL LOWER FORK HARDWARE

7. Install one Lower Lock Nut to each Collet Tube. Hand Tighten.
Figure 3



Figure 3

ADJUSTABLE- SELECT BEST LOCATION

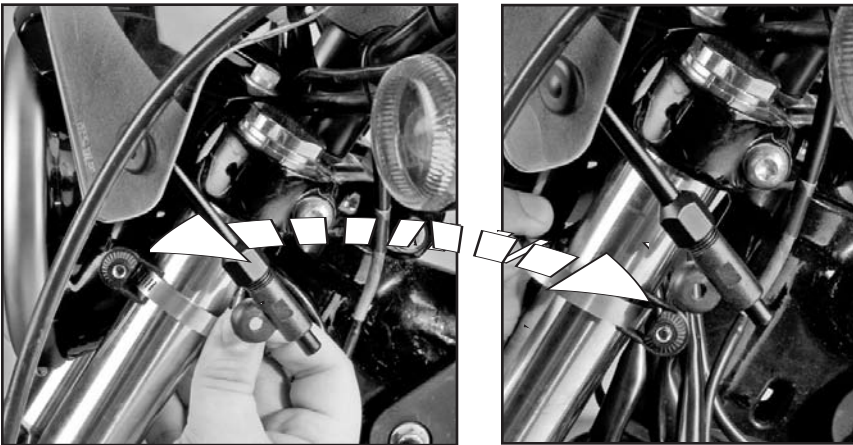

Figure 4

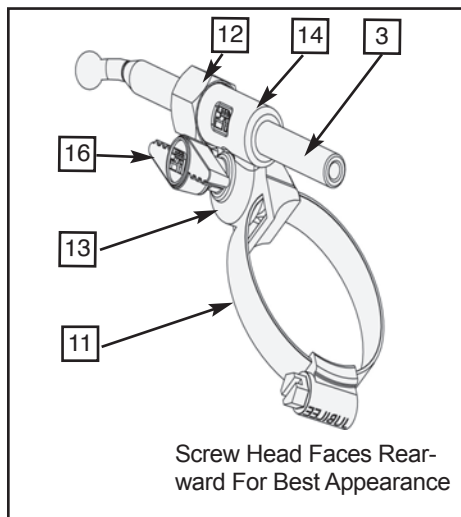

Figure 4a

8. Slide the Left Collet Tube onto the Left Lower Rod. Determine where to mount the Fork Boss. **Figure 4 and 4a**

9. Thread one Fork Boss through a hose clamp. Loosely attached Hose Clamp to fork. Screw head of Hose Clamp faces to the rear of the motorcycle. (Flat Blade Screw Driver) **Figure 4 and 4a**

CHECK CLEARANCE and TIGHTEN HARDWARE

10. When the desired height and position of the screen is adjusted, carefully move the front forks left and right to make sure the Upper Rods and the Lower Rods **Do Not** contact the frame or gas tank. If the Rods are too long, they can be trimmed with a fine hacksaw blade and touched up with a rust-inhibiting black paint.

TIGHTEN HARDWARE

11. Fully tighten:

- A. Whizlok Nuts on Eyebolts (9/16" Box Wrench)
- B. Wing Screws on Lower Fork Boss
- C. Fork Hose Clamps on Fork (Flat Blade ScrewDriver)

ENJOY YOUR NEW STREET SHIELD™ WINDSHIELD



Ask for Shield Wash™ and RainZip® at your local dealer or visit www.nationalcycle.com.

CLEANING AND MAINTENANCE

To clean the screen, wash with a clean soft cloth, plenty of warm water and if necessary, a non-abrasive soap such as dishwashing liquid. Flannel or soft chamois make good cleaning cloths. **Paint, glue residue or grease removal:** Moisten cotton with naphtha or turpentine followed by a wash as above.

National Cycle **Shield Wash™** (N1401-01) makes a good daily cleaner and comes with a handy travel size bottle. Shield Wash is safe for all windshields and helmet visors.

Do not clean polycarbonate in hot sun or high temperatures. Do not clean the screen with glass cleaners.

Do not allow brake fluid, alcohol, or strong solvents to contact the screen.

RAIN REPELLENT

Do not use rain protective products made for glass. We recommend National Cycle's **RainZip®** (N1410-01) to keep your windshield clear in rainy weather.



Register your windshield online at www.nationalcycle.com

National Cycle 3-Year Limited Warranty

National Cycle hereby warrants to the original registered owner of a National Cycle polycarbonate windshield for a period of three years from the date of purchase against breakage. This limited warranty is expressly limited to the replacement of the polycarbonate windshield. This limited warranty does not include scratches, coating failure, cosmetic wear and tear, replacement of hardware, or any consequential damages or expenses including labor cost of installation, removal and/or replacement, inconvenience, inbound freight expenses or damage to any other component of the motorcycle or any other accessories. Certain chemicals, generally known as acidic hydrocarbons, are known to cause polycarbonate damage and will not be covered under this limited warranty. Please refer to the cleaning instructions supplied with all National Cycle windshields.

Visit www.nationalcycle.com for further details, or call or write National Cycle

! WARNING

Never ride your motorcycle with loose accessory mounting hardware. Check the hardware for tightness regularly.

Today's motorcycles are built with enough frame rigidity to withstand the moderate loads imposed on them by the foreseeable addition of an accessory(ies). If an accessory(ies) adversely affects your motorcycle's stability, immediately remove the accessory(ies). Do not ride a motorcycle that exhibits unsafe handling traits.

Have experienced service personnel correct any problem before riding with the accessory(ies) installed. For further questions concerning handling problems associated with an accessory(ies), contact your dealer, motorcycle manufacturer, or accessory manufacturer.

Sunlight reflected off the inside curvature of the windshield can, at certain times of day, cause extreme heat buildup on the motorcycle instruments and possibly even melt them. Exercise care in parking to avoid this. Park your motorcycle facing the sun or place an opaque object over this area.