

Thank you for purchasing a National Cycle product. Read these instructions carefully and thoroughly before beginning work. Dealers, if installing this windshield for a customer, please give them this manual upon completion. It contains information needed to properly maintain and use this product.

PARTS LIST

ITEM	PART NO.	DESCRIPTION	QUANTITY
A		Windshield	1
B	37-370820-000	Mounting Bracket; Left	1
C	37-370821-000	Mounting Bracket; Right	1
BAG#350			
D	50-505201-000	Screw, Hex M8 x 45mm	2
E	42-433030-001	Nut, Whizlock, M8 x 1.25	2
F	37-370822-000	Face Plate	2
G	42-471200-000	Wellnut	4
H	55-581005-000	Screw, Philips, 10-32 x 5/8	4
I	55-586033-000	Screw, Carriage, 1/4-20	2
J	37-370824-000	Clamp	2
K	49-490521-000	Washer, Flat	2
L	42-430000-001	Nut, Whizlock, 1/4-20	2



TOOLS REQUIRED:

- #2 or #3 Philips Screwdriver
- 10mm/12mm Wrench
- 13mm Wrench

NOTE:

This product is intended to fit more than one model of bike. Installation and adjustment may vary depending on model.

PREPARATION

Carefully unpack your new windshield, sort the parts, and make sure you have everything required to complete the assembly.



Step 1

ASSEMBLY

Step 1

Insert the four Wellnuts (G) into the two Mounting Brackets (B, C). To ease assembly, lubricate the exterior of the Wellnuts with some saliva or water. Do not use oil of any kind.

The Mounting Brackets are now ready for assembly to the windshield.

Step 2

Lay the Windshield (A) on a soft, padded work surface. You will also need two Face Plates (F), four 10-32 x 5/8 Philips Screws (H), and a Philips screwdriver.

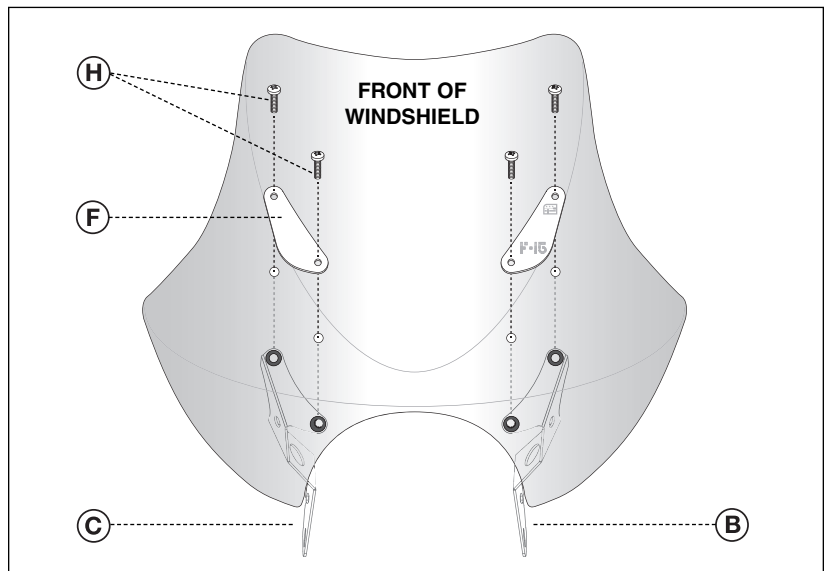

Step 2

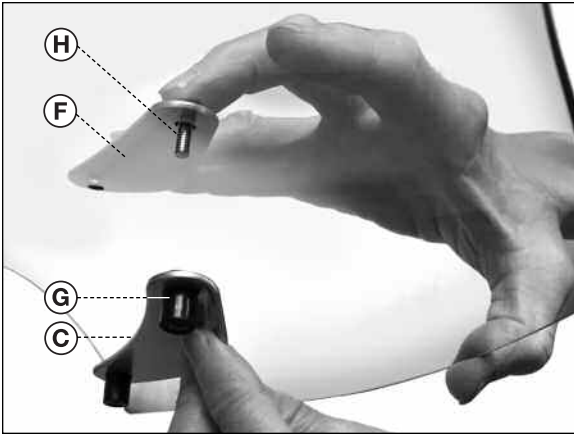

Step 3

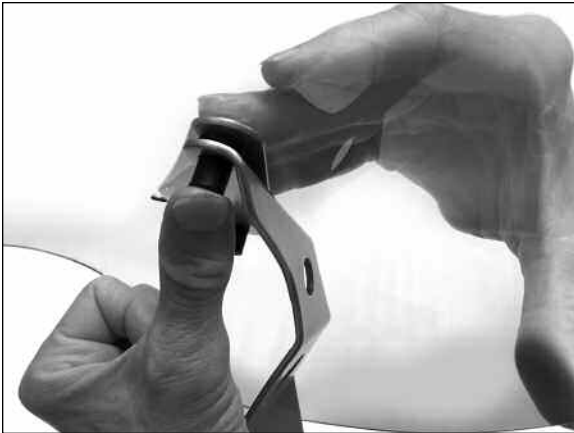

Step 4



Step 5

ASSEMBLY, CONT'D

Step 3

Insert one 10-32 x 5/8 Philips Screws (H) through one hole in the Face Plate (F), and then through a hole in the Windshield.

NOTE: Face Plates and Mounting Brackets are in left/right pairs. Refer to Figure 2 to determine proper position.

Step 4

Position the Mounting Bracket with installed Wellnuts to the screw on the inside of the Windshield. Hold in position in preparation for tightening.

Step 5

Push firmly on the Wellnut as you tighten the screw with a Philips screwdriver. You will need to push firmly until the threads engage.

Align the Face Plate and the Mounting Bracket to the remaining hole and insert another screw and tighten it.

When the screws are fully tightened, the Wellnuts will expand and grip as shown in *Illustration A*.

Step 6

Repeat Steps 3-5 on the other half of the Windshield. Make sure all screws are firmly tightened.

The Windshield assembly is now complete and you are ready to install it on your motorcycle.

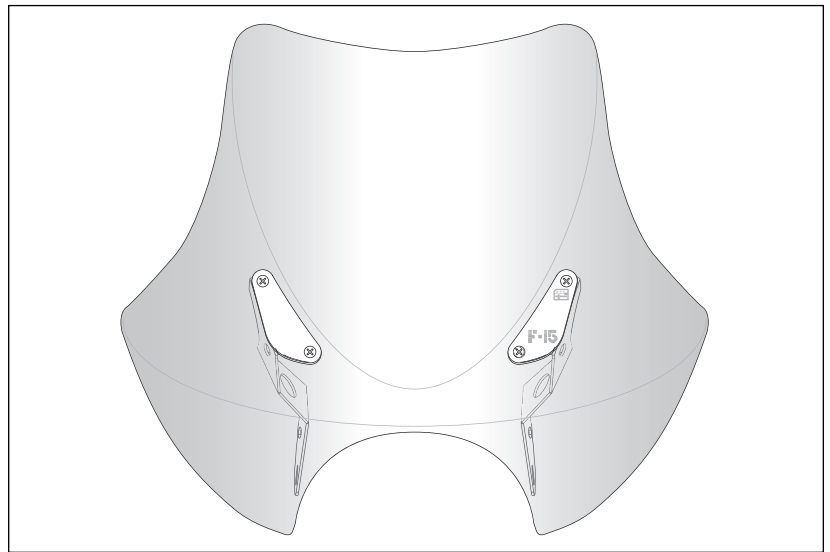
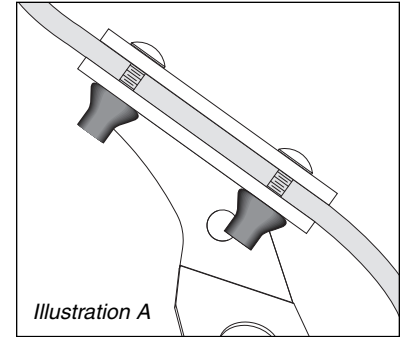

Step 6

PREPARATION

Position the motorcycle securely on its stand or a work stand. Cover the front fender to protect it from dropped tools, etc.

Remove the headlight from the headlight shell. It is not necessary to remove the wires. Just let the headlight hang carefully over the front wheel.

Loosen but do not remove the left and right mounting bolts holding the headlight shell to the left/right ears or brackets.

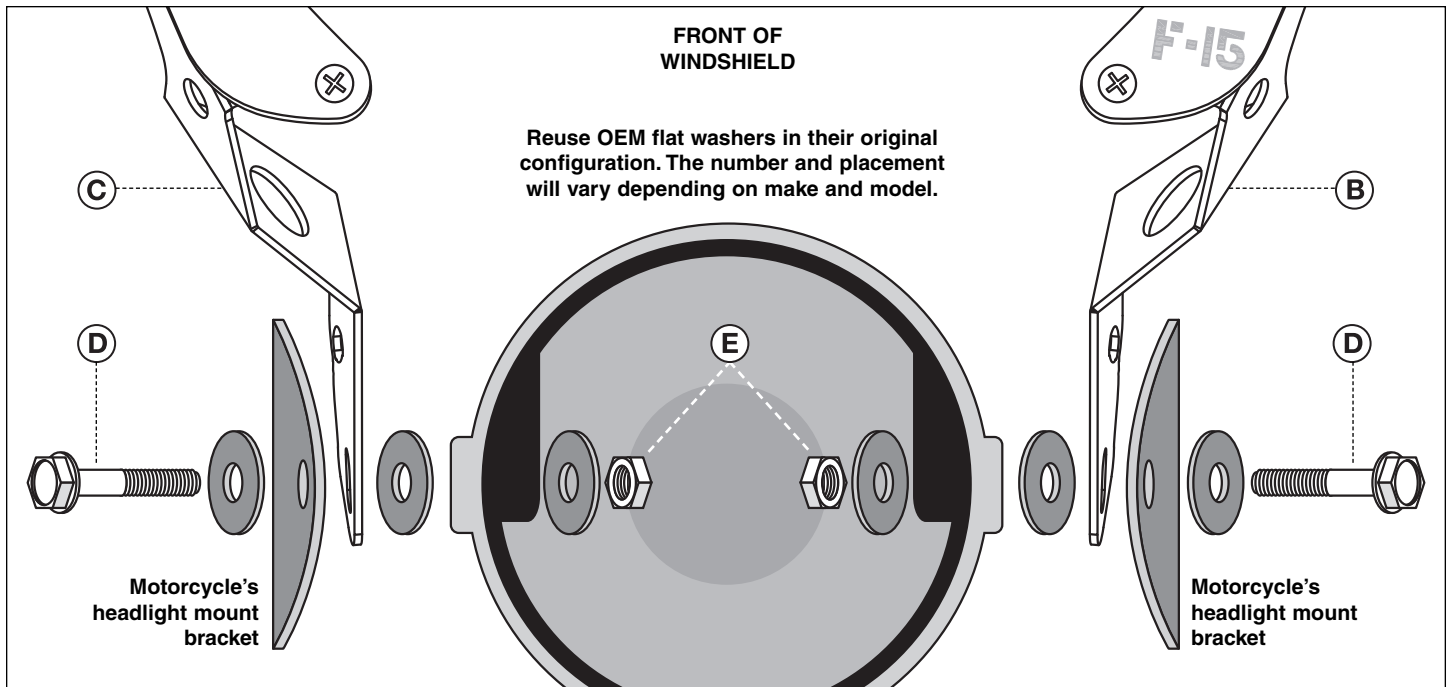

Step 7

INSTALLATION

Step 7

Remove the headlight shell mounting bolt, washers and any related hardware from one side of the headlight shell and slide the Windshield's Mounting Bracket between the headlight shell and the headlight ear or bracket.

Reinsert the mounting bolt, keeping any washers or spacers in their original orientation. The hardware goes through the lower slotted holes of the Mounting Bracket (B, C) as shown in *Illustration B*.

Finger tighten bolt and nut.

NOTE: If the original mounting bolt is not long enough, use the M8 x 45mm Hex Screw (D) and M8 x 1.25 Whizlock Nut (E) that is included in this Windshield's mounting hardware.

Repeat the same procedure on the other side of the headlight shell.

Adjust the height and rake angle of the Windshield/Mounting Bracket assembly to the position you prefer, then firmly tighten the bolts and nuts inside and outside the headlight shell and headlight mount ears.

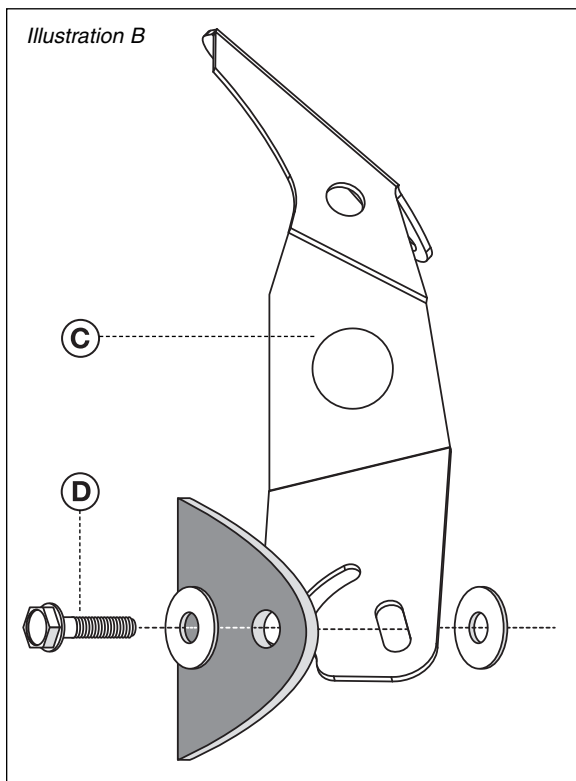

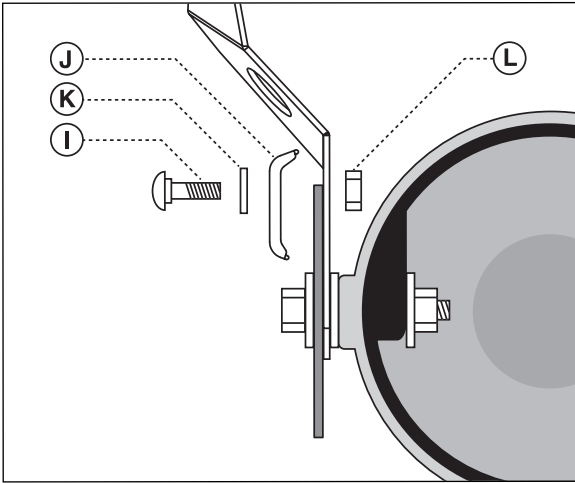

Step 8

INSTALLATION, CONT'D

Step 8

Position one Clamp (J) over the motorcycle's headlight mounting bracket and align the Clamp's hole with the upper curved slot on the Mounting Bracket as shown in *Illustration C*.

Insert a 1/4-20 Carriage Screw (I) and Flat Washer (K) through the hole in the Clamp and through the curved slot in the Mounting Bracket.

Secure with a 1/4-20 Whizlock Nut (L).

Repeat the procedure on the other side of the motorcycle.

Double-check the height and rake angle of the windshield. Make sure there is no interference with the motorcycle's control cables. Make adjustments if necessary.

Check to make sure that all fasteners are firmly tightened.

Reinstall the headlight into the headlight shell.

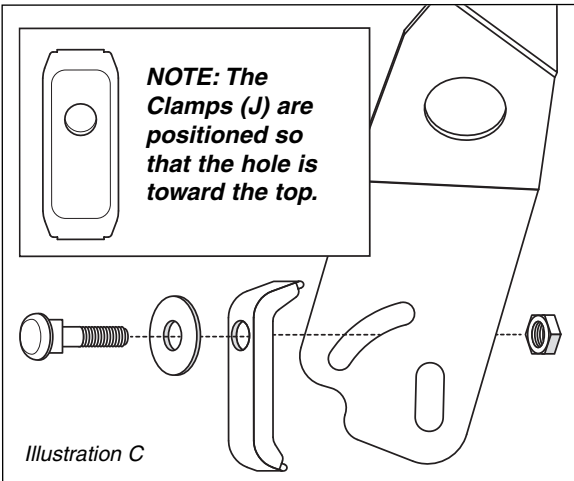

Congratulations! Your National Cycle F-Series™ F-15 Windshield is installed and you are ready to ride!



Ask for Shield Wash™ and RainZip® at your local dealer or visit www.nationalcycle.com.

CLEANING AND MAINTENANCE

To clean your windshield, wash with a clean soft cloth and plenty of warm water and, if necessary, a non-abrasive soap such as dishwashing liquid. Flannel or soft chambrais make good cleaning cloths. **Paint, glue residue or grease removal:** Moisten cotton wad with naphtha or turpentine followed by a wash as above.

National Cycle **Shield Wash™** (N1401-01) makes a good daily cleaner and comes with a handy travel-size bottle. Shield Wash is safe for all windshields and helmet visors.

Do not clean windshields in hot sun or high temperatures. Do not clean the screen with household glass cleaners.

Do not allow brake fluid, alcohol, or strong solvents to contact the windshield.

RAIN REPELLENT

Do not use rain protective products made for glass. We recommend National Cycle's **RainZip®** (N1410-01) to keep your windshield clear in rainy weather.

WARNING

Never ride your motorcycle with loose accessory mounting hardware. Check the hardware for tightness regularly.

Today's motorcycles are built with enough frame rigidity to withstand the moderate loads imposed on them by the foreseeable addition of an accessory(ies). If an accessory(ies) adversely affects your motorcycle's stability, immediately remove the accessory(ies). Do not ride a motorcycle that exhibits unsafe handling traits.

Have experienced service personnel correct any problem before riding with the accessory(ies) installed. For further questions concerning handling problems associated with an accessory(ies), contact your dealer, motorcycle manufacturer, or accessory manufacturer.

Sunlight reflected off the inside curvature of the windscreen can, at certain times of day, cause extreme heat buildup on the motorcycles instruments and possibly even melt them. Exercise care in parking to avoid this. Park your motorcycle facing the sun or place an opaque object over this area.