



**KIT-CIN**  
**Mounting Hardware Kit for Narrow Frame**  
**Heavy Duty Windshields,**  
**N2220, N2221, and N2290**  
**to Indian Scout**

Thank you for purchasing a National Cycle product. Read these instructions carefully and thoroughly before beginning work. Dealers, if installing this windshield for a customer, please give them this manual. It contains information needed to properly maintain and use this product.



**Attention:**

Special notes and cautionary measures which can prevent damage to the accessory or motorcycle.



**Note:**

Tips for facilitation of operation, control and adjustment, as well as maintenance work.

**CONTENTS OF KIT**

Item	Description	Part No.	Qty.	Notes and Tools
1	Bracket Inner	37-370010-000	2	
2	Bracket, Outer Left	37-370011-CNL	1	
3	Bracket, Outer Right	37-370011-CNR	1	
<b>Bag#131</b>				
4	Spacer	49-495512-000	4	
5	Screw, M6 x 12	51-516612-000	4	4mm Hex Key
6	Screw, M6 x 40	51-518240-000	4	4mm Hex Key
7	Bracket, Flat	37-410504-000	2	
8	Nut, Hex Cap w/ Flange	42-483006-000	8	10mm Box Wrench

**BAG#131**



**TOOLS**

- 7/16" Box Wrench
- Phillips Screw Driver
- 4mm Hex Wrench
- 10mm Box Wrench
- Torque Wrench In/Lbs



Left and right side of motorcycle is determined from the rider's perspective while sitting on the motorcycle.

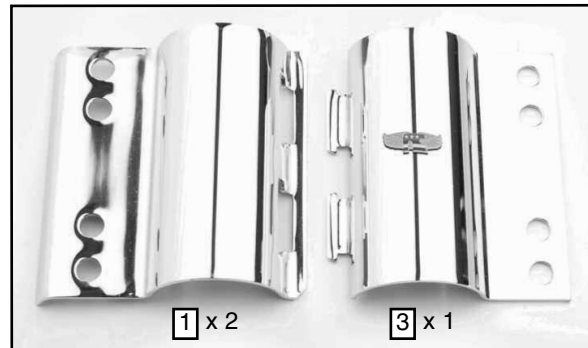
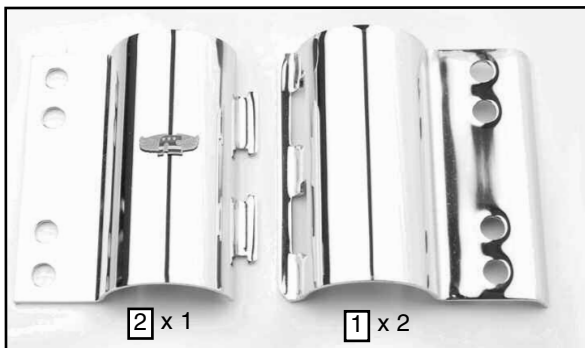

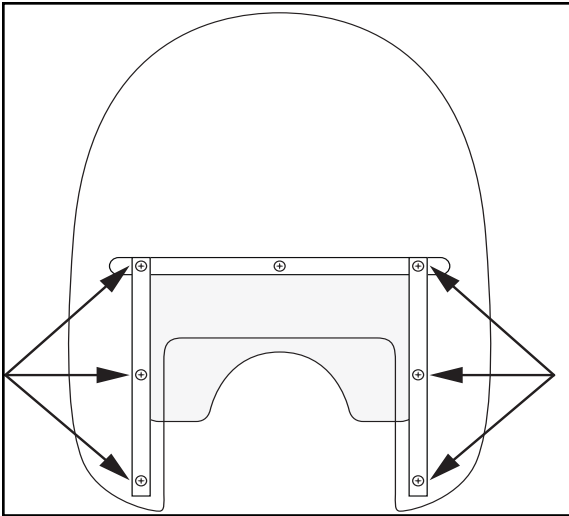

Illustration A.

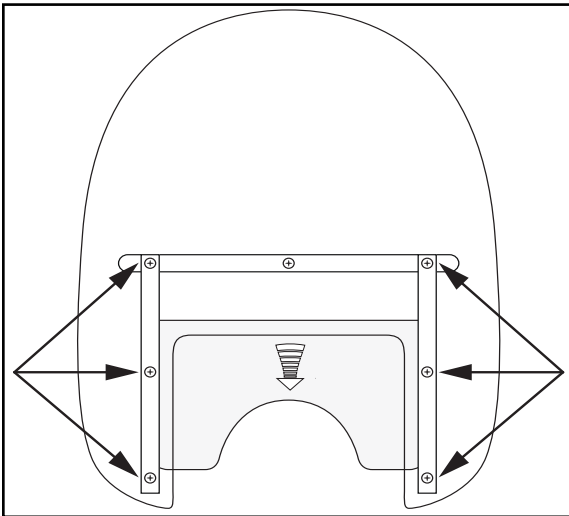



Illustration B. Adjustable Window in Lowered position

## PREPARATION

1. Position motorcycle securely on its side stand.

 To install the Heavy Duty Windshield to the Indian Scout, the adjustable window needs to be in the lowest position.

## Adjust Window

1. Loosen the 6 cap nuts on the vertical chrome strips. With both hands pull the Adjustable Window down to within 1/2" of the Windshield cutout.

### Illustration A and B

(Phillips Screw Driver and 7/16" Box Wrench)

2. Tighten cap nuts to 3-10 In/Lbs of resistance to turning screw. (3-10 In/Lbs after the screw has passed the Nylok Patch.

### Illustration B

## INSTALLATION

### Install Brackets To Forks

1. Place an Inner Bracket (1) onto the inside of the Left fork. Hook Left Outer bracket tabs (2) into Inner Bracket slots.

2. Install Bracket at the center 2 holes with M6 x 12 Screws (5) and Cap Nuts (8).

#### Illustration C

3. Hand tighten cap nuts at this time. Repeat procedure for right side.

4. Adjust brackets to locate them just under the upper triple clamp. Check symmetry of brackets. Right and Left Clamps must be parallel and pointing forward.

#### Illustration C and Figure 1

5. Fully tighten the M6 x 12 Screws and Cap Nuts.

(Hex Wrench and 10mm Box Wrench)

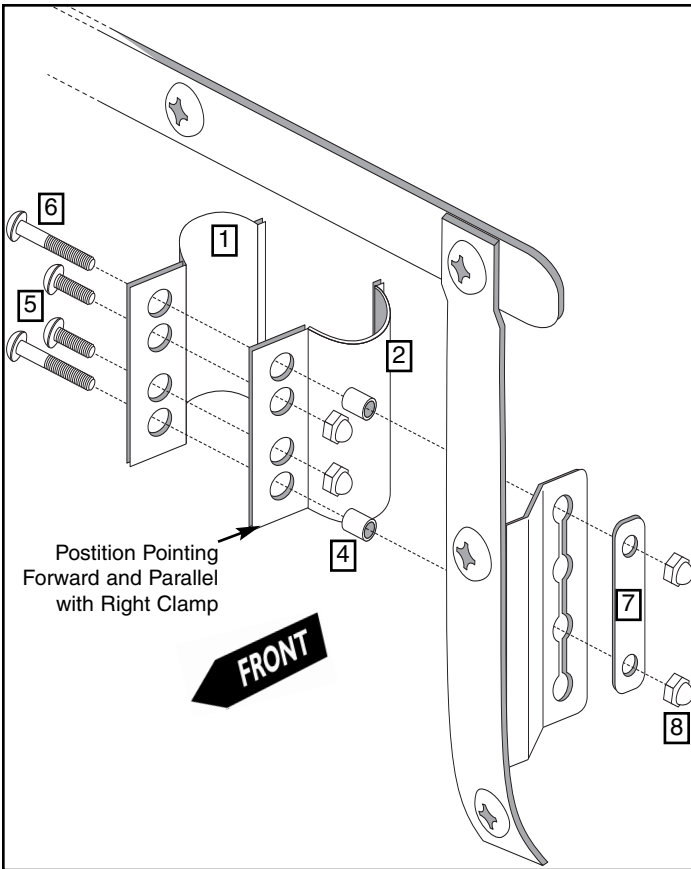

Illustration C. Left side of motorcycle



Figure 1. Left side of motorcycle

### Install Windshield To Brackets

6. Install Windshield onto Brackets using Spacers (4), M6 x 40 Screws (6) and Flat Plate (7). Secure with Cap Nuts (8).

#### Illustration C and Figure 1

(Hex Key and 10mm Box Wrench)

7. Make final adjustments. Check symmetry of left and right sides. Check clearance at full fork lock left and right. Adjust if necessary. Fully tighten the M6 x 40 Screws and Cap Nuts.



Ask for Shield Wash™ and RainZip® at your local dealer or visit [www.nationalcycle.com](http://www.nationalcycle.com).

## CLEANING AND MAINTENANCE

To clean the screen, wash with a clean soft cloth, plenty of warm water and if necessary, a non-abrasive soap such as dishwashing liquid. Flannel or soft chamois make good cleaning cloths. **Paint, glue residue or grease removal:** Moisten cotton with naphtha or turpentine followed by a wash as above.

National Cycle **Shield Wash™** (N1401-01) makes a good daily cleaner and comes with a handy travel size bottle. Shield Wash is safe for all windshields and helmet visors.

Do not clean polycarbonate in hot sun or high temperatures. Do not clean the screen with glass cleaners.

Do not allow brake fluid, alcohol, or strong solvents to contact the screen.

## RAIN REPELLENT

Do not use rain protective products made for glass. We recommend National Cycle's **RainZip®** (N1410-01) to keep your windshield clear in rainy weather.



Register your Heavy Duty windshield online at [www.nationalcycle.com](http://www.nationalcycle.com)

### National Cycle 3-Year Limited Warranty

National Cycle hereby warrants to the original registered owner of a National Cycle polycarbonate windshield for a period of three years from the date of purchase against breakage. This limited warranty is expressly limited to the replacement of the polycarbonate windshield. This limited warranty does not include scratches, coating failure, cosmetic wear and tear, replacement of hardware, or any consequential damages or expenses including labor cost of installation, removal and/or replacement, inconvenience, inbound freight expenses or damage to any other component of the motorcycle or any other accessories. Certain chemicals, generally known as acidic hydrocarbons, are known to cause polycarbonate damage and will not be covered under this limited warranty. Please refer to the cleaning instructions supplied with all National Cycle windshields.

Visit [www.nationalcycle.com](http://www.nationalcycle.com) for further details, or call or write National Cycle

## ⚠ WARNING

Never ride your motorcycle with loose accessory mounting hardware. Check the hardware for tightness regularly.

Today's motorcycles are built with enough frame rigidity to withstand the moderate loads imposed on them by the foreseeable addition of an accessory(ies). If an accessory(ies) adversely affects your motorcycle's stability, immediately remove the accessory(ies). Do not ride a motorcycle that exhibits unsafe handling traits.

Have experienced service personnel correct any problem before riding with the accessory(ies) installed. For further questions concerning handling problems associated with an accessory(ies), contact your dealer, motorcycle manufacturer, or accessory manufacturer.

Sunlight reflected off the inside curvature of the windshield can, at certain times of day, cause extreme heat buildup on the motorcycle instruments and possibly even melt them. Exercise care in parking to avoid this. Park your motorcycle facing the sun or place an opaque object over this area.