

INSTALLATION OF SADDLE BAG TO FRAME

Rest the stainless steel clips attached to the outside of the bag to the lower section of the frame. Engage the quarter turn fastener to the frame. Push in and turn clockwise one quarter turn. There will be a slight spring pressure against the fastener, turn until it stops. Grab the side of the bag, wiggle it. The bag should be firmly set. If fastener is loose, repeat installation of bag to frame.

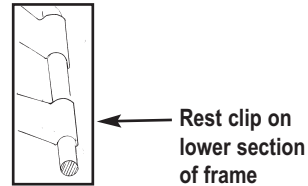

Saddlebag Care: Wash with a mild soap or detergent and warm water. Use a soft cloth. To remove tar use naphtha or turpentine.



Painting: Lightly sand the surface with 600 grit sandpaper and spray lacquer, urethane or other paint.

Replacement Parts: Contact National Cycle, Inc.

WARNING

Not to exceed 11 lbs (5kg) weight per bag. Do not exceed 80 mph (129 kph) when saddlebags are mounted.

On some motorcycles, additional accessories can reduce a motorcycle's stability and safe operating speed. Never ride a motorcycle that exhibits any unsafe handling characteristics. Remove all accessories and cargo at once. Have your dealer diagnose and solve the problem before remounting your accessories.

INSTALLATION OF SADDLE BAG TO FRAME

Rest the stainless steel clips attached to the outside of the bag to the lower section of the frame. Engage the quarter turn fastener to the frame. Push in and turn clockwise one quarter turn. There will be a slight spring pressure against the fastener, turn until it stops. Grab the side of the bag, wiggle it. The bag should be firmly set. If fastener is loose, repeat installation of bag to frame.

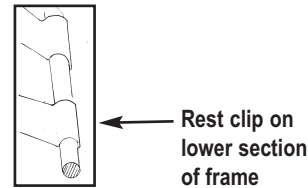

Saddlebag Care: Wash with a mild soap or detergent and warm water. Use a soft cloth. To remove tar use naphtha or turpentine.



Painting: Lightly sand the surface with 600 grit sandpaper and spray lacquer, urethane or other paint.

Replacement Parts: Contact National Cycle, Inc.

WARNING

Not to exceed 11 lbs (5kg) weight per bag. Do not exceed 80 mph (129 kph) when saddlebags are mounted.

On some motorcycles, additional accessories can reduce a motorcycle's stability and safe operating speed. Never ride a motorcycle that exhibits any unsafe handling characteristics. Remove all accessories and cargo at once. Have your dealer diagnose and solve the problem before remounting your accessories.

INSTALLATION INSTRUCTIONS Harley-Davidson® Sportster '94-current Installation Kit SB403

10-111403 02-99



NATIONAL CYCLE, INC.

PO Box 158
Maywood, IL 60153-0158 USA
708-343-0400 Fax:708-343-0625
E-Mail: info@nationalcycle.com
<http://www.nationalcycle.com>

INSTALLATION INSTRUCTIONS Harley-Davidson® Sportster '94-current Installation Kit SB403

10-111403 02-99



NATIONAL CYCLE, INC.

PO Box 158
Maywood, IL 60153-0158 USA
708-343-0400 Fax:708-343-0625
E-Mail: info@nationalcycle.com
<http://www.nationalcycle.com>

INSTALLATION OF MOUNTING BRACKETS

1. Remove Seat Assembly
2. Disconnect Turn signal Wires, refer to Service Manual.
3. Remove mounting bolts for fender strut covers (Wrench 1/2")
4. Remove Turn signal, refer to Service Manual.
5. Remove Turn signal mounting bolt, replace with 5/16-18 x 1" Hex Bolt (3), use original nut (Wrench, 1/2").
6. Assemble Turn signal to Relocation Bracket (4) using 5/16-24 x 2 3/4" Hex Screws (2) (Wrench, 1/2").

Someone to help hold the Turn signal Relocation Bracket into position will be useful in step 7.

7. Assemble Relocation Bracket to Fender Strut (**outside of OEM Backrest Side Support if used ***) using Saddle Bag Mounting Bracket and supplied screws (5/16-18 x 2 1/4") (1) and original equipment locking nuts (Wrench, 1/2").
8. Tighten Mounting Bracket Screws to 30 ft.lbs. (4.5m-kg) torque.
9. Re-route Turn signal Wires under seat (same routing as original,) and reconnect. Verify operation of turnsignals and if necessary correct before riding.
10. Repeat on other side of motorcycle.

Tools Needed

Wrench, 1/2" (2)
Hex Key, 1/4"
Motorcycle's service manual

Parts List

Index	Description	Qty.
1	Screws, Hex Socket 5/16-18 x 2 1/4"	4
2	Screws, Hex, 5/16-24 x 2 3/4"	2
3	Screws, Hex, 5/16-18 x 1"	2
4	Brackets, T-S Relocation	2
5	Mount, Saddle Bag, Right	1
6	Mount, Saddle Bag, Left	1

* Purchase from a hardware store 3 1/4" Socket Screws to use in place of the 2 1/4" Socket Screws when mounting Cruiselineer™ Bags with the Harley-Davidson® detachable back rest.

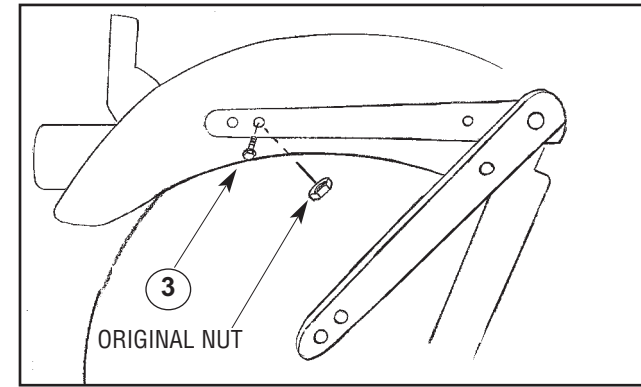

STEP 6.

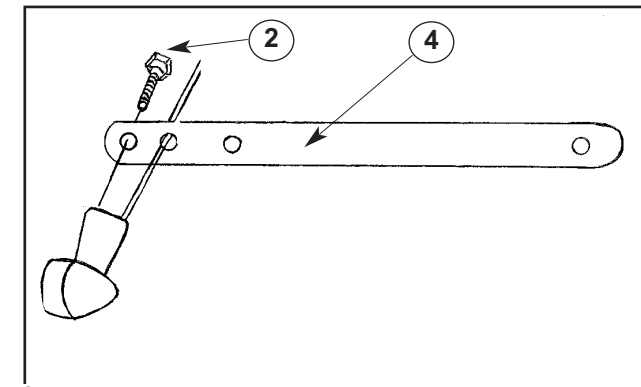

STEP 7.

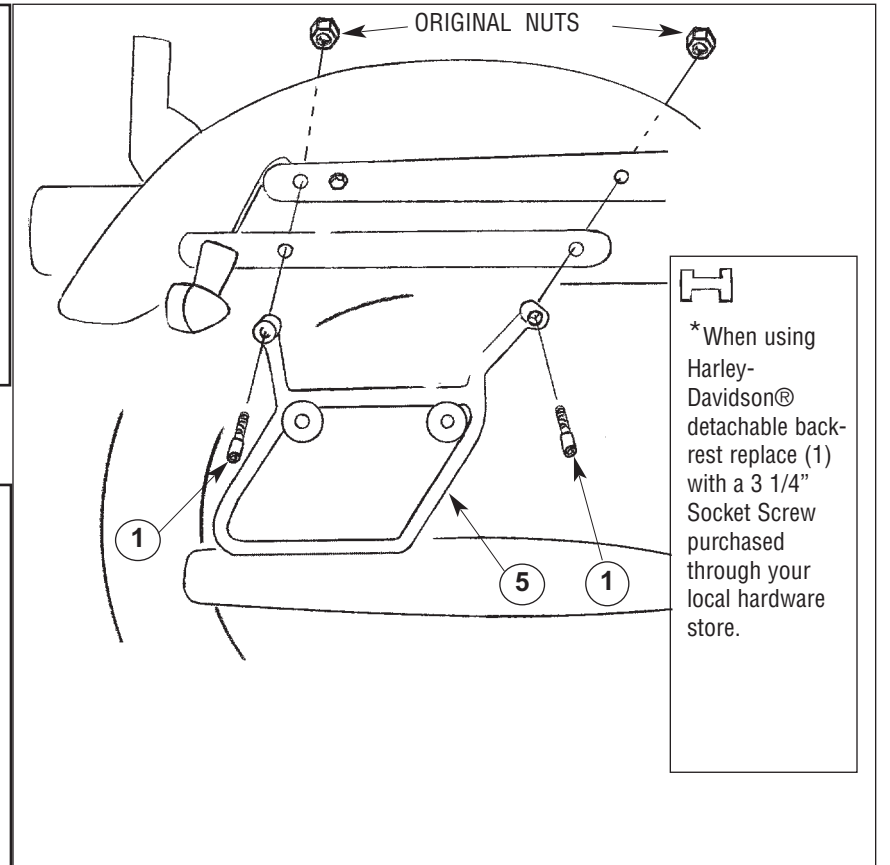

*When using Harley-Davidson® detachable backrest replace (1) with a 3 1/4" Socket Screw purchased through your local hardware store.

INSTALLATION OF MOUNTING BRACKETS

1. Remove Seat Assembly
2. Disconnect Turn signal Wires, refer to Service Manual.
3. Remove mounting bolts for fender strut covers (Wrench 1/2")
4. Remove Turn signal, refer to Service Manual.
5. Remove Turn signal mounting bolt, replace with 5/16-18 x 1" Hex Bolt (3), use original nut (Wrench, 1/2").
6. Assemble Turn signal to Relocation Bracket (4) using 5/16-24 x 2 3/4" Hex Screws (2) (Wrench, 1/2").

Someone to help hold the Turn signal Relocation Bracket into position will be useful in step 7.

7. Assemble Relocation Bracket to Fender Strut (**outside of OEM Backrest Side Support if used ***) using Saddle Bag Mounting Bracket and supplied screws (5/16-18 x 2 1/4") (1) and original equipment locking nuts (Wrench, 1/2").
8. Tighten Mounting Bracket Screws to 30 ft.lbs. (4.5m-kg) torque.
9. Re-route Turn signal Wires under seat (same routing as original,) and reconnect. Verify operation of turnsignals and if necessary correct before riding.
10. Repeat on other side of motorcycle.

Tools Needed

Wrench, 1/2" (2)
Hex Key, 1/4"
Motorcycle's service manual

Parts List

Index	Description	Qty.
1	Screws, Hex Socket 5/16-18 x 2 1/4"	4
2	Screws, Hex, 5/16-24 x 2 3/4"	2
3	Screws, Hex, 5/16-18 x 1"	2
4	Brackets, T-S Relocation	2
5	Mount, Saddle Bag, Right	1
6	Mount, Saddle Bag, Left	1

* Purchase from a hardware store 3 1/4" Socket Screws to use in place of the 2 1/4" Socket Screws when mounting Cruiselineer™ Bags with the Harley-Davidson® detachable back rest.

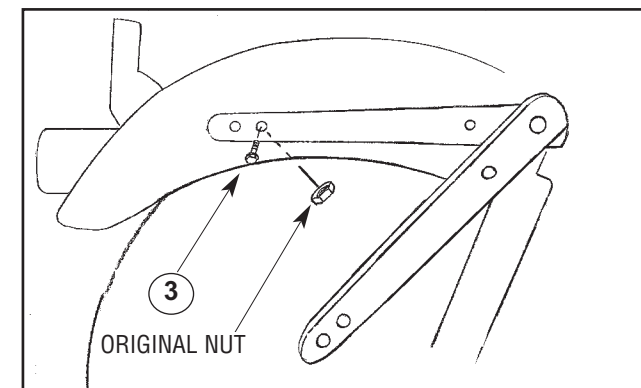

STEP 6.

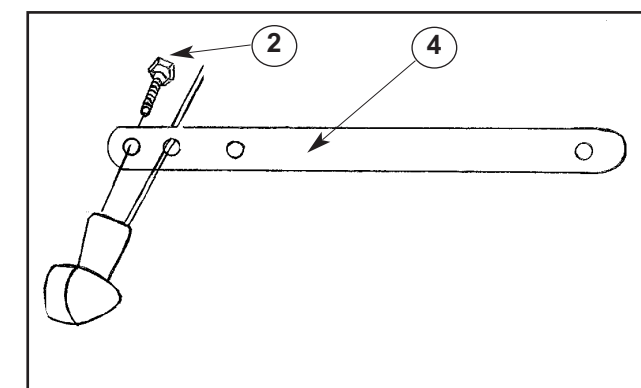

STEP 7.

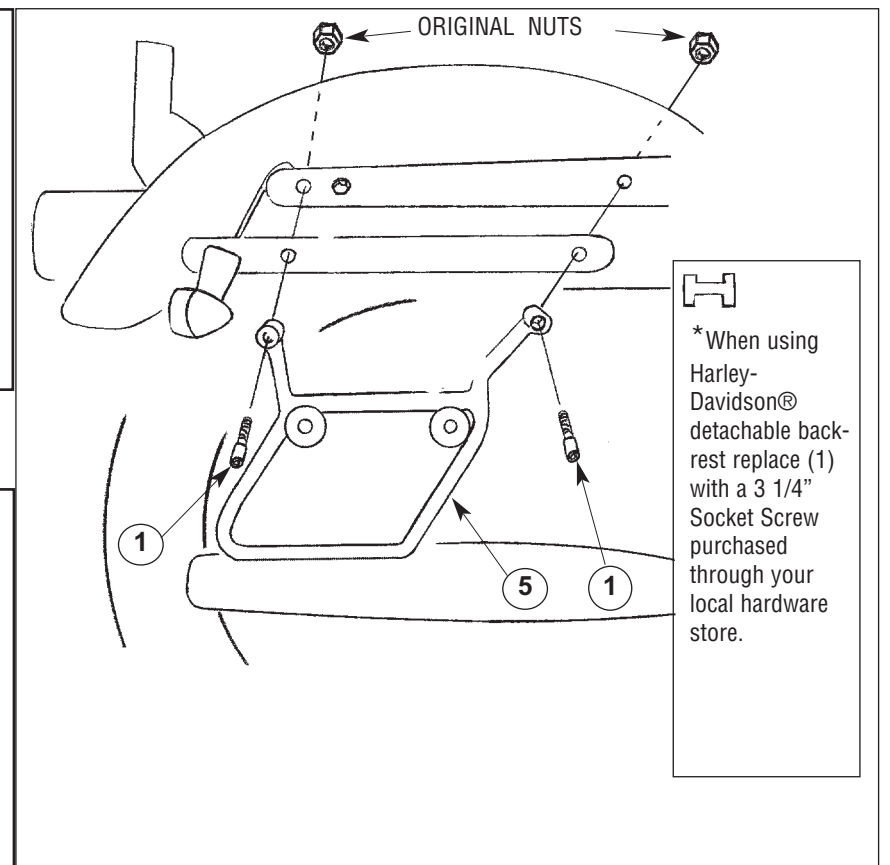

*When using Harley-Davidson® detachable backrest replace (1) with a 3 1/4" Socket Screw purchased through your local hardware store.